

QUALITY



METAL

WORKS

SHIPBOARD HABITABILITY NAVSEA FURNITURE

CONTENTS

Contents	IV
Beds and Berths	1
Furnishing-Stateroom and Berthing	16
Seating	46
Tables	49
Desk	76
Stowage-General	84

BED-CABIN STATEROOM

Berth, Officer's, Size 1 & 2, Single or Double

Bed, Cabin-Stateroom

Intended Use:
In Senior Officer Cabin Stateroom
Manufacturer: **QUALITY METAL WORKS**
SFC No. B-1A-1
Hull Type Drawing No. 805-1749028
NSN: NONE
Size -Millimeters (Inches)

Principal Material:
Aluminum, high pressure laminate
Remarks:
Headboard case is divided into 3 compartments.
Outer sections have sliding doors.
Center compartment is open and has built-in reading lamp.
Top of headboard case: high pressure plastic laminate.
Box Spring and mattress are included.

ORDER OPTIONS

Bed-standard or long (Bed is designed to accommodate a type 1, size 10 standard mattress or Type 1, size 10 modified to 84-1/4" long for long bed. See Section 1D, Sheet 1.) Top-high pressure plastic laminate manufacturer, color, and number.

Order Options:
Size - Millimeters, (inches)

Item	Length Length	Width	Height
Standard Bed Complete as shown	2240 (88-1/4)	1250 (49-1/4)	610 (24)
Long Bed Complete as shown	2390 (94-1/4)	1250 (49-1/4)	610 (24)
Box Spring Standard	1960 (77-1/4)	1200 (47-1/4)	200 (8)
Box Spring Long	2110 (83-1/4)	200 (47-1/4)	200 (8)
Mattress Standard	1960 (77-1/4)	1220 (48)	170 (6-1/2)
Mattress Long	2110 (83-1/4)	1220 (48)	170 (6-1/2)



Item	NSN	Length	Width	Height
Sgl, Size 1	H2090-00-826-1855	2070 (81-1/2)	830 (32-1/2)	650 (25-5/8)
Dbl, Size 1 (shown)	H2090-00-826-1897	2070 (81-1/2)	830 (32-1/2)	1570 (61-3/4)
Spring Unit, Size 1	H2090-00-754-4428	1930 (76)	710 (28)	80(3)
Sgl, Size 2	H2090-00-826-1856	2070 (81-1/2)	1000 (39-1/4)	650 (25-5/8)
Dbl, Size 2	H2090-00-826-1857	2070 (81-1/2)	1000 (39-1/4)	1570 (61-3/4)
Spring Unit, Size 2	H2090-00-754-4429	1930 (76)	880 (34-3/4)	80 (3)



Berth, Officer's, Size 1 & 2, Single or Double

Intended Use: In Staterooms
Manufacturer: **QUALITY METAL WORKS**
SFC No. B-1A-2

Hull Type Drawing No.
No. 805-1631103 (Size 1) 805-1634193 (Size 2) 805-1632586 (Spring Unit)

Principal Material: Aluminum
Remarks:
Size 2 berths (the larger size) should be specified, space permitting.
Size 1 berths (the smaller) should only be selected for compartments that cannot accommodate size 2 berths.
Three drawers, providing 10.76 cubic feet of storage space, and sub-bases are included.

Removeable panels under spring of bottom berths provide access to end drawers when the fronts are obstructed.

Lee rails are removeable.
Berths are designed to accommodate the following mattress sizes in accordance with specification MIL-M-18351:
Size 1 berth: Type III, Size 1
Size 2 berth: Type III, Size 2

ORDER OPTIONS:
Berth - Single or Double.
Mattress - See Section 1D, Sheet B-1D-1.
Springs - Size 1 or Size 2
Specify ladder when ordering double berth. Ladder to be manufactured in accordance with MIL-PRF-3203B.
Berth lights, if required should be specified, in accordance with MIL-F-16377/17.

Berth, Transom, Officer, Types L36 &

Berth, Transom, with Fold-Away Table

Berth, Transom, Officer, Types L36 & L36-W31

Intended Use:
In Senior Officer Quarters and Commanding Officer's Sea Cabin

Manufacturer: **QUALITY METAL WORKS**

SFC No. B-1A-3
Hull Type Drawing No.
No. 805-1637198 Type L36 Transom Berth
(As Shown) 805-1637197 Type L36-W31
Double Transome Berth
NSN: 2090-00-865-9490 (Single)

Principal Material:
Aluminum, upholstery, and cushioning.

Remarks:
Lee rails and drawers provided.
Built-in springs.
Double Transom Berth L36-W31 provides an additional berth mounted above the transom berth shown.

ORDER OPTIONS:
Berth-single or double.
Upholstery-vinyl or fabric.
Upholstery-color and pattern.
Matterress-see Section B-1D-1.

Item	Length	Width	Height
Berth, Transom, Single (shown)	2110 (83)	1080 (42-3/8)	1240 (48-3/4)
Berth, Transom Double	2110 (83)	1080 (42-3/8)	2090 (82-5/16)



OPEN



CLOSED

Item	Length	Width	Height
Berth, Transom, Dimensions to face of bulkhead	2060 (81)	640 (25)	1190 (47)
Bulkhead cut-out for case	2000 (78-11/16)	230 (9)	750 (29-7/16)



Berth, Transom, with Fold-Away Table
Intended Use:
In Submarine Commanding Officer Spaces
Manufacturer: **QUALITY METAL WORKS**
SFC No. B-1A-4
Hull Type Drawing No. No. 805-1645143
NSN: NONE
Principal Material: Corrosion Resistant Steel, aluminum, upholstery, and cushioning
Remarks: This dual purpose item is easily converted from living to berthing by folding the table, backs of seats and unlatching the berth unit (see inset). Berth has counterbalance springs and a spring-loaded latching device. Stowage compartments are provided under the seat cushions and beneath the berth case recess. Knock down construction for passage thru a 25" dia hatch. Fold-away table has high pressure laminate top. Lee rails not provided
Cushioning: Per MIL-STD-1623
Upholstery: Expanded vinyl or woven fabric per MIL-STD-1623.

ORDER OPTIONS:
Specify type of upholstery vinyl or fabric.
Specify color and pattern for upholstery.
Specify high pressure laminate - manufacturer, color, and number.
Specify mattress if required, see Section B-1D-1.

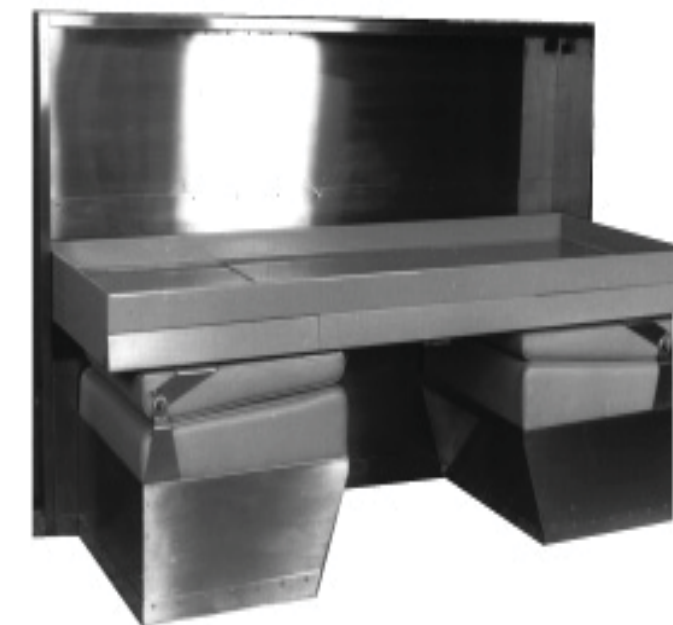

Berth, Modular, Lightweight

Berth, Modular, Lightweight

Intended Use:

In Enlisted Berthing Spaces

Manufacturer: **QUALITY METAL**

WORKS

SFC No.

B-1B-1 1 of 5

Hull Type Drawing No. 804-

5959312

NSN:

Principal Material:

Aluminum

Remarks:

BERTH, MODULAR, LIGHTWEIGHT

The illustration shown is a typical crew modular berth. The CPO modular berth is similar. Various styles, representing different configurations are depicted and described on the following data sheets. These berths replace CPO and crew berths, drawings, NAVSEA No. 804-5184205, 804-1409485, and 804-2229637.

Order Options:

The following berth components

may be ordered separately:

- Lee Strap Assembly, NSN 1H

2090-01-283-3362

- Light fixture, NSN 1H 2090-01-

279-9740

- Kick Out Panel and Frame, NSN

1H 2090-01284-4307



Berth, Modular, Lightweight

		Mattress	Length			Width	Height
Type	Style	Clearance	Size 1	Size 2	Size 3		
I	1	460 (18)	1920 (75-3/4)	2010 (79-1/4)	2110 (83-1/4)	700 (27-3/4)	2140 (84-1/4)
	2	510 (20)	1920 (75-3/4)	2010 (79-1/4)	2110 (83-1/4)	700 (27-3/4)	2290 (90-1/4)
II	1	460 (18)	1920 (75-3/4)	2010 (79-1/4)	2110 (83-1/4)	700 (27-3/4)	1970 (77-3/4)
	2	510 (20)	1920 (75-3/4)	2010 (79-1/4)	2110 (83-1/4)	700 (27-3/4)	2130 (83-3/4)
III	1	460 (18)	1920 (75-3/4)	2010 (79-1/4)	2110 (83-1/4)	700 (27-3/4)	1780 (70-1/4)
	2	510 (20)	1920 (75-3/4)	2010 (79-1/4)	2110 (83-1/4)	700 (27-3/4)	1940 (76-1/4)
IV	1	460 (18)	1920 (75-3/4)	2010 (79-1/4)	2110 (83-1/4)	700 (27-3/4)	1780 (70)
	2	510 (20)	1920 (75-3/4)	2010 (79-1/4)	2110 (83-1/4)	700 (27-3/4)	1930 (76)

Berth, Modular, Lightweight

Berth, Modular, Lightweight

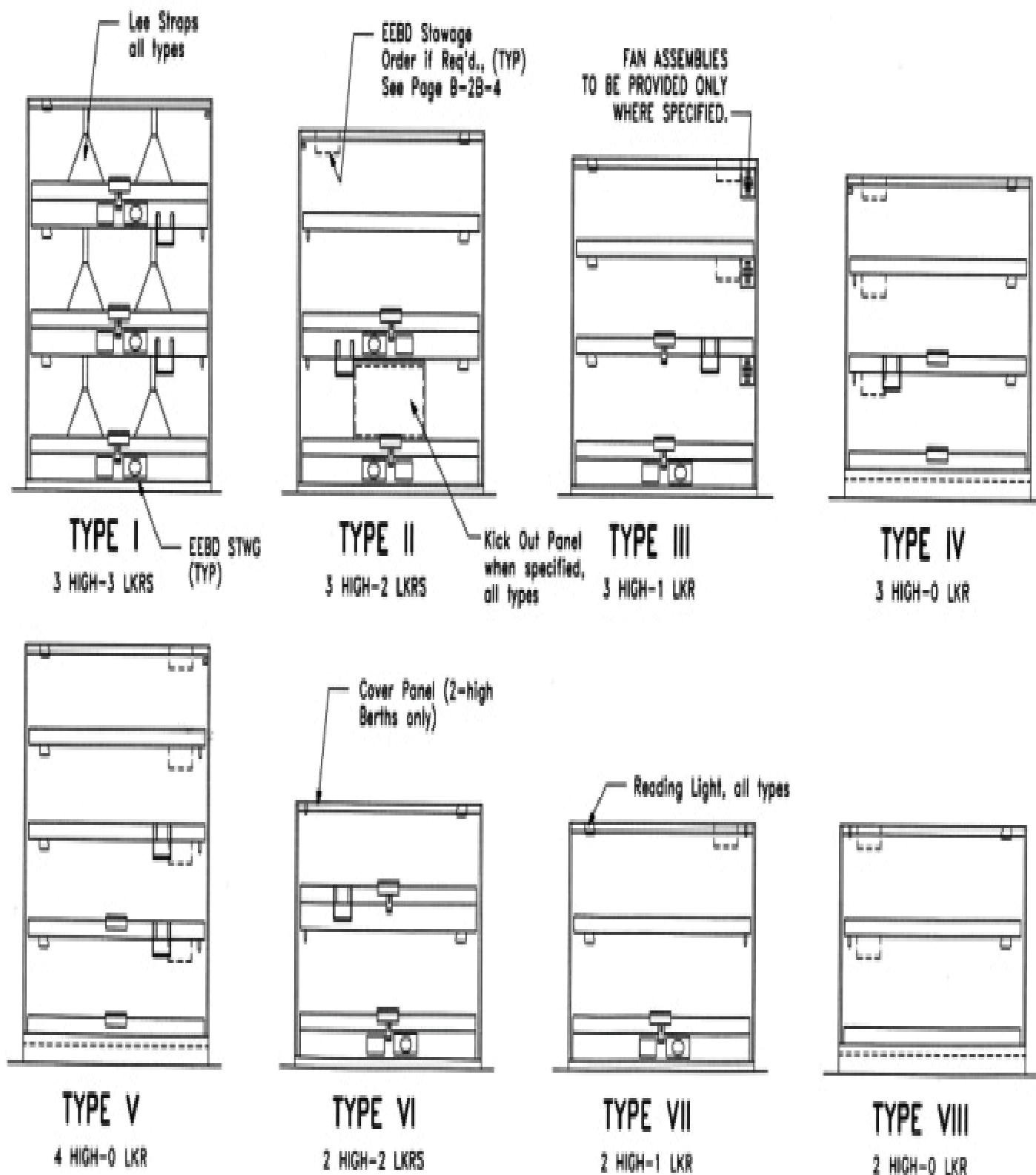

Berth, Modular, Crew and Troop (cont'd)

Intended Use:
In crew and troop berthing spaces
Manufacturer: QUALITY METAL WORKS

SFC No. B-1B-1 3 of 5
Hull Type Drawing No. 804-5959312
NSN:
Principal Material: Aluminum

Remarks:
Berths are designed to accommodate following mattresses in accordance with specification MIL-M-18351 (see 1D-1 when ordering mattresses.)
Size 1 Berth: Type 1, Size 1 mattress. Size 2 Berth: Type 1, Size 2 mattress.
Size 3 Berth: Type 1, Size 3 mattress.
Mattress clearance is measured from top of mattress to underside of berth or locker over or to top of berth enclosure for upper berth.
Whenever a berth is provided without a locker under, locker of equal volume shall be provided.

Order Options:
Ordering Information must include the following:
Type, Style, Size, and Hull Type Drawing Number.
Units can be ordered without back and end panels to save weight.
Fan Units.
Curtains and track see sheet B-2B-3

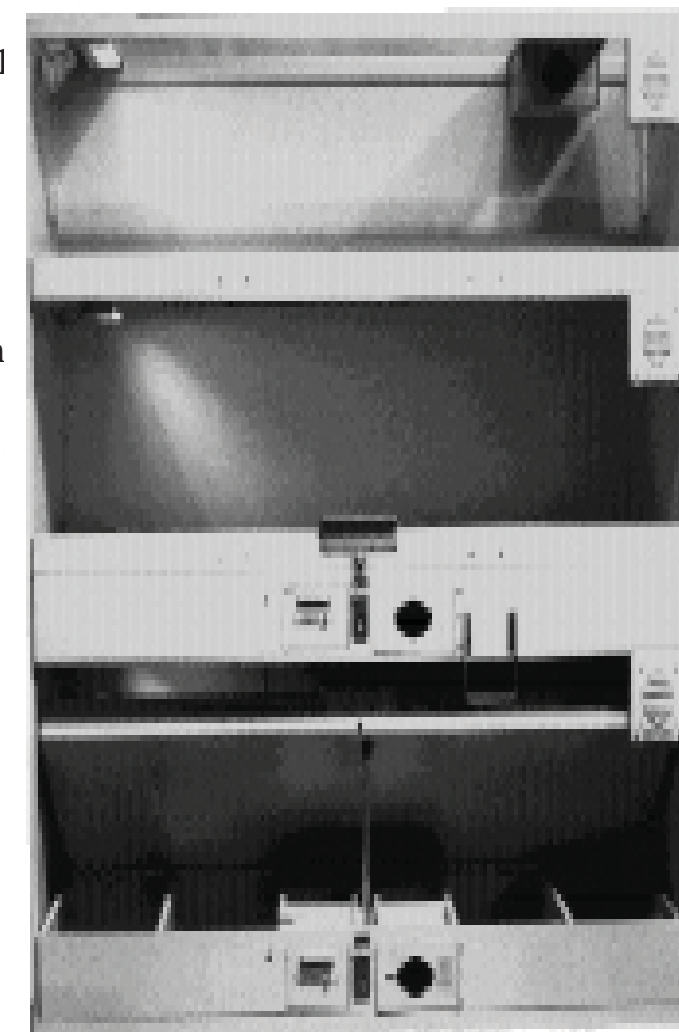

Berth, Modular, Lightweight

Berth, Modular, Lightweight

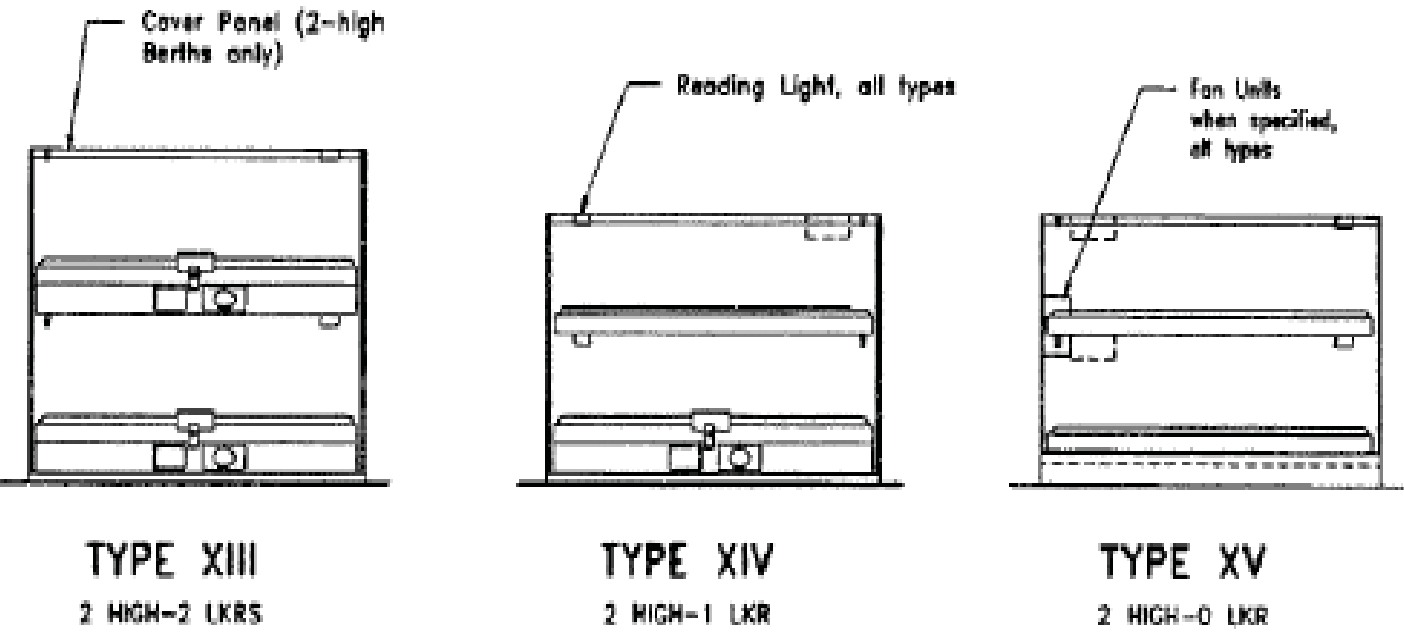
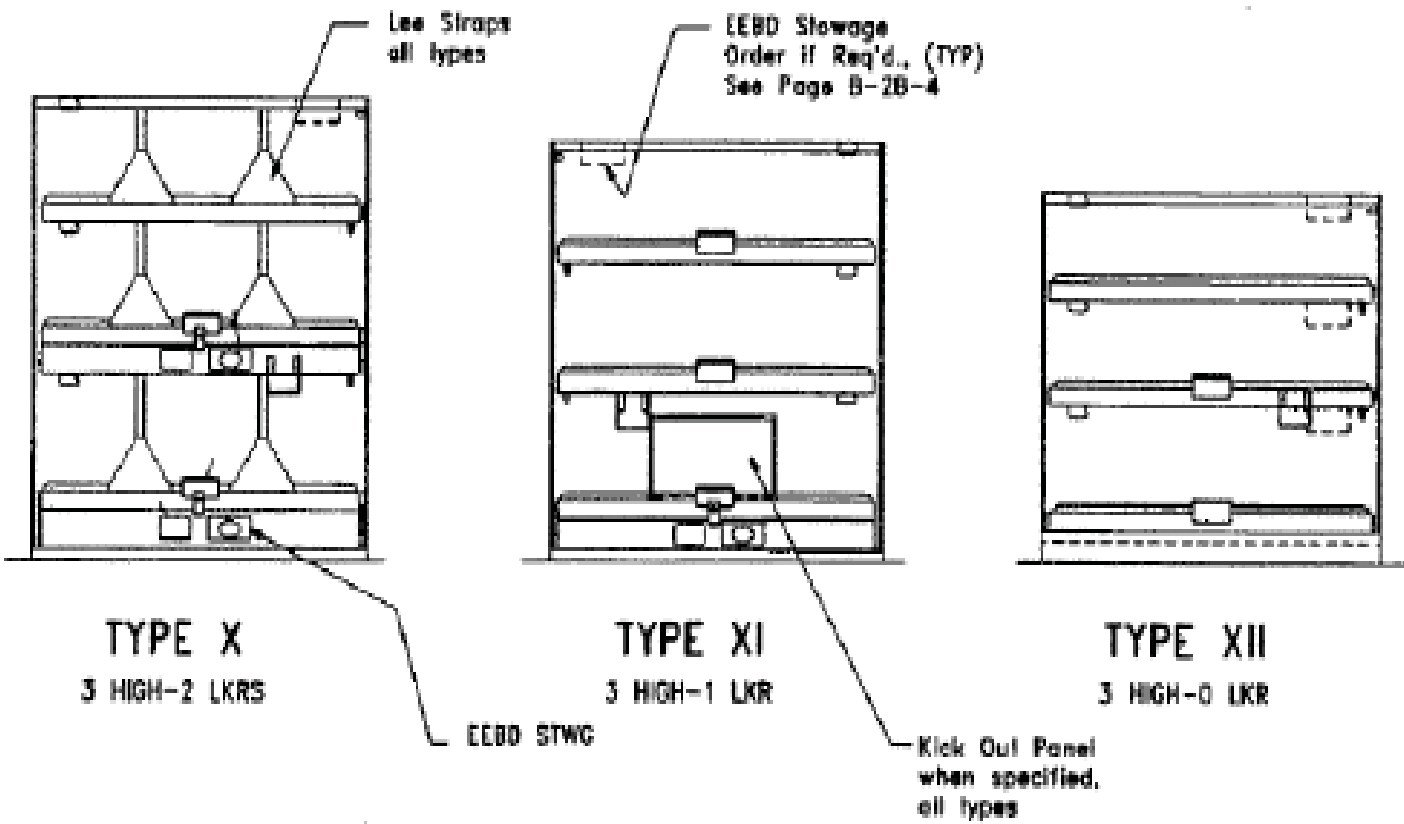

Type	Style	Mattress	Lenght		Width		Height
		Clearance	Size 4	Size 5	Size 6		
X	2	510 (20)	2010 (79-1/4)	2110 (83-1/4)	760 (29-3/4)	2280 (89-3/4)	
XI	2	510 (20)	2010 (79-1/4)	2110 (83-1/4)	760 (29-3/4)	2080 (81-3/4)	
	3	580 (23)	2010 (79-1/4)	2110 (83-1/4)	760 (29-3/4)	2310 (90-3/4)	
XII	2	510 (20)	2010 (79-1/4)	2110 (83-1/4)	760 (29-3/4)	1980 (78)	
	3	580 (23)	2010 (79-1/4)	2110 (83-1/4)	760 (29-3/4)	2210 (87)	

Berth, Modular, CPO
 Intended Use:
 In CPO and SNCO Berthing Spaces
 Manufacturer:
 SFC No.
 B-1B-1 4 of 5
 Hull Type Drawing No.
 804-5959312
 NSN:
 None

Berth, Modular, Lightweight

Type	Style	Mattress	Length		Width	Height
		Clearance	Size 4	Size 5		
XII	2	510 (20)	2010 (79-1/4)	2110 (83-1/4)	760 (29-3/4)	1670 (65-3/4)
	3	580 (23)	2010 (79-1/4)	2110 (83-1/4)	760 (29-3/4)	1820 (71-3/4)
XIV	2	510 (20)	2010 (79-1/4)	2110 (83-1/4)	760 (29-3/4)	1470 (57-3/4)
	3	580 (23)	2010 (79-1/4)	2110 (83-1/4)	760 (29-3/4)	1620 (63-3/4)
XV	2	510 (20)	2010 (79-1/4)	2110 (83-1/4)	760 (29-3/4)	1370 (54)
	3	580 (23)	2010 (79-1/4)	2110 (83-1/4)	760 (29-3/4)	1520 (60)

Berth, Modular, CPO (cont'd)

Intended Use:

In CPO and SNCO berthing spaces

Manufacturer: **QUALITY METAL WORKS**

SFC No. B-1B-1 5 of 5

Hull Type Drawing No.

NSN:

Principal Material:

Remarks:

Berths are designed to accommodate the following mattresses in accordance with specification-MIL-M-18351 (see 1D-1 when ordering mattress.)

Size 4 berth: Type II, Size 1 mattress.

Size 5 berth: Type II, Size 2 mattress.

Mattress clearance is measured from top of mattress to underside of berth of locker over, or to top of berth enclosure for upper berth. The hand of berth is dependent upon placement of accessories at time of installation.

Order Options:

Ordering information must include following:

Type, Style, Size, and Hull Type Drawing Number. Units can be ordered without back and end panels to save weight.

Fan Units Curtains and track see B-2B-3

Berth, Submarine, with Lockers Under

		Berth Type	Length		Height
SSN	Officer	C	1970 (77-1/2)	700 (27-1/2)	170 (6-1/2)
	Crew	A	1890 (71-1/2)	650 (25-1/2)	170 (6-1/2)
SSBN	Officer & CPO	C	1970 (77-1/2)	700 (27-1/2)	170 (6-1/2)
	Crew	B	1970 (77-1/2)	650 (25-1/2)	170 (6-1/2)

Berth, Submarine, with Lockers Under

Intended Use:

In Berthing Spaces on Submarines

Manufacturer: **QUALITY METAL WORKS**

SFC No. B-1B-2

Hull Type Drawing No.

805-1630197

NSN:

None

Principal Material:

Aluminum

Remarks:

Size – millimeters, (inches)

Locker, including drawer has approximately four cubic feet of stowage space.

Bottom berth trices up for maintenance.

Two shoe cases shown at the foot ends of

Intermediate and upper berths serve occupants of the lower and intermediate berths

Shoe case for occupant of the upper berth is

Secured to the overhead structure.

Sizes listed in the descriptive data above are approximate.

Order Options:

See Hull Type Drawer No. 805-1630197 prior to ordering as sizes very slightly dependent upon type of submarine in which the berths will be installed.

Mattresses to be ordered separate. (See B-1D-1).

Berth lights, ordered separately, shall be in accordance with Military Specification MIL-F-16377/77.

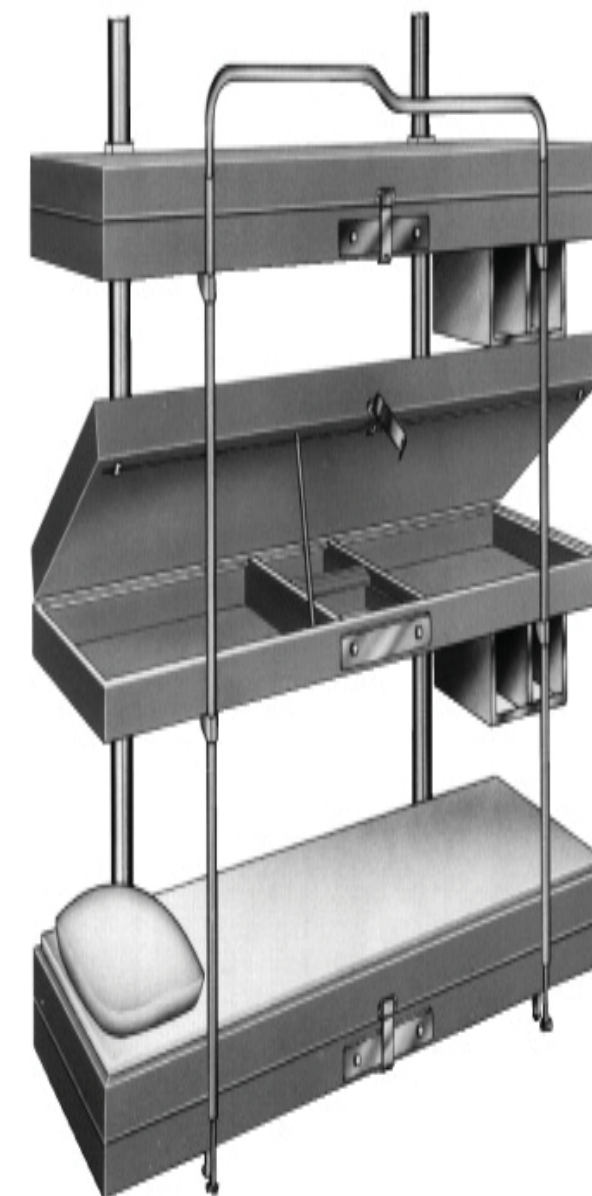

Berth, Submarine, without Lockers

		Berth Type	Length		Height
SSN	Officer	C	1970 (77-1/2)	700 (27-1/2)	170 (6-1/2)
	Crew	A	1890 (71-1/2)	650 (25-1/2)	170 (6-1/2)
SSBN	Officer & CPO	C	1970 (77-1/2)	700 (27-1/2)	170 (6-1/2)
	Crew	B	1970 (77-1/2)	650 (25-1/2)	170 (6-1/2)

Berth, Submarine, without Lockers Under
 Intended Use: In Berthing Spaces on submarines
 Manufacturer: **QUALITY METAL WORKS**
 SFC No. B-1B-3
 Hull Type Drawing No.
 No. 805-1630197, 805-1630198 (Details)
 NSN:
 NONE

Principal Material: Aluminum
 Remarks:
 Sizes listed in descriptive data above are approximate.
 Bottom berth trices up for deck maintenance.
 Individual berth pans are approximately 29 pounds in weight.

ORDER OPTIONS:
 See Hull Type Drawing 805-1630197 prior to ordering as sizes vary slightly dependent upon type of submarine in which the berths will be installed.
 Mattresses to be ordered separately. (See B-1D-1)
 Berth lights to be ordered separately, shall be in accordance with Military Specification MIL-F-16377/17.

Order Options:
 See Hull type Drawings 805-1630197 prior to ordering as sizes vary slightly dependent upon type of submarine in which the berths will be installed.

Mattresses to be ordered separately. (See B-1D-1).

Berth lights to be ordered separately, shall be in accordance

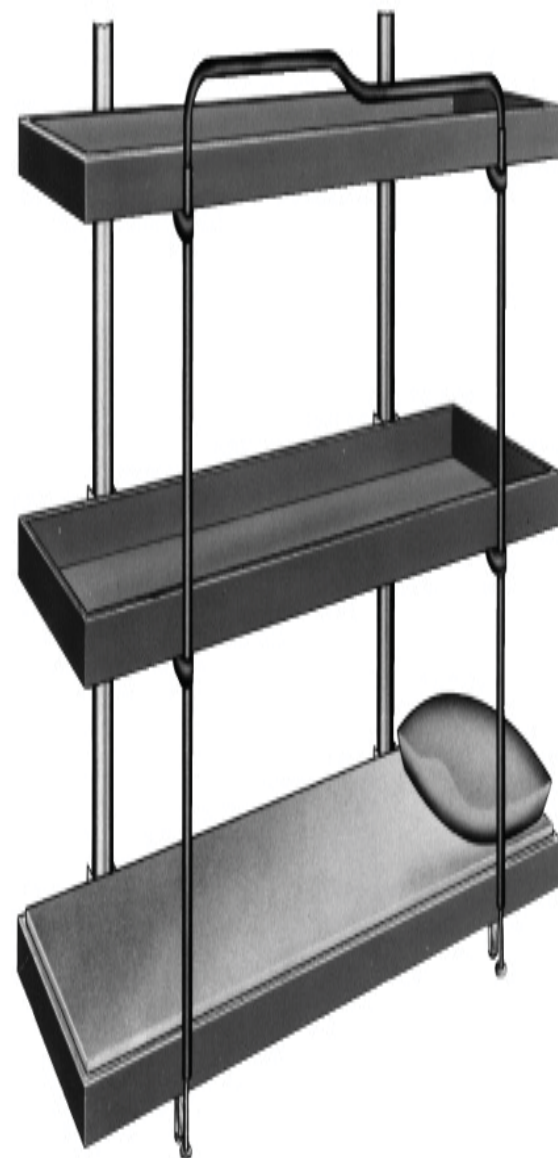

Berth, Folding Pullman Type

Item	SFC No.	Length	Width	Height
Berth	B-1B-4	2040 (80-1/2)	800 (31-1/2)	770 (30-1/4)

Berth, Folding Pullman Type
 Intended Use:
 Crew and Officer Living Spaces
 Manufacturer: **QUALITY METAL WORKS**
 SFC No. B-1B-4
 Hull Type Drawing No.
 No. NONE
 NSN: NONE

Principal Material:
 Aluminum
 Remarks:
 Folded thickness 8-1/2".
 Gas spring assist to down and up position.
 Knob locks for positive locking in stowed position.
 High pressure plastic laminate for bulkhead panel seen in open position.
 Frame-baked enamel or powder coated.
 Unit-installed flush mounted to bulkhead.

ORDER OPTIONS:
 Frame - color and finish
 Bulkhead panel - high pressure plastic laminate manufacturer, color, and number

Order Options:
 Frame - color and finish
 Bulkhead panel-high pressure plastic laminate manufacturer, color and number.

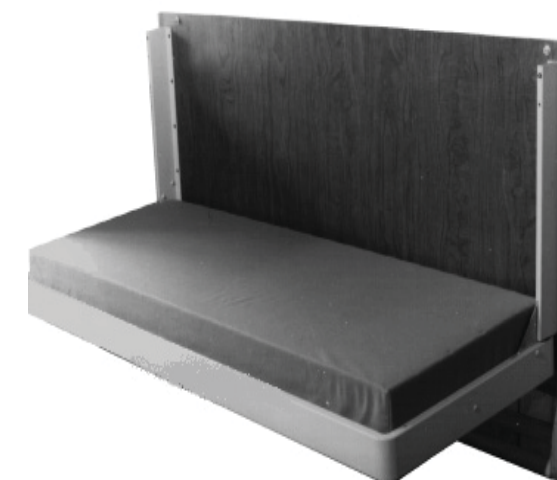

Berth, Hospital

Item	Width	Length	Height
Single tier unit	930 (36-5/8)	2040 (80-1/4)	deck/deck
Double tier unit	1780 (70)	2040 (80-1/4)	deck/deck
Lower berth			330-480 (13-19)*
Upper berth			910-1,1070(36-42)*

Berth, Hospital
 Intended Use:
 In Hospital Wards
 Manufacturer: **QUALITY METAL WORKS**
 SFC No. B-1C-1
 Hull Type Drawing No.
 No. 805-1641006
 NSN: NONE
 Principal Material: Aluminum
 Remarks:
 Full height stanchions.
 Lower berth fitted with gatch frame which is adjustable for patient comfort.
 Berth hinge up for deck maintenance and additional working room.
 When double tier unit is ordered, privacy partitions and berth end partitions are required.
 See Hull Type Drawing Nos. 805-1646044, 805-1646045, and 805-2214469.
 *Minimum/maximum heights above deck.

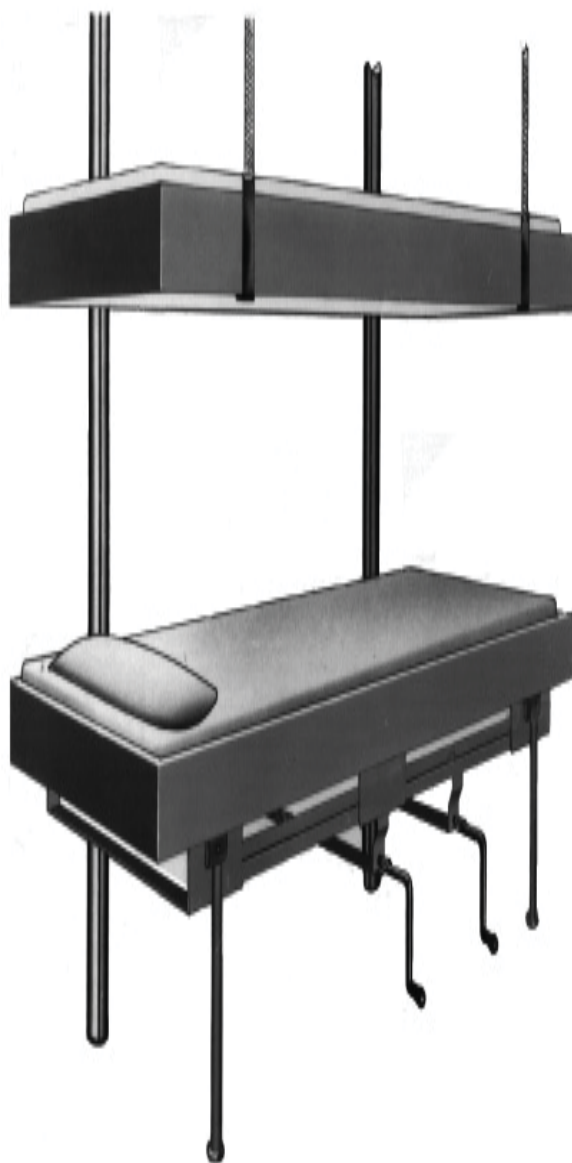

ORDER OPTIONS:
 Mattress should be specified if required (see Sheet B-1D-1).
 Locker should be specified if required (see Sheet B-7A-10).

Case, Toilet Article

Width	Depth	Height
530 (21)	140 (5-3/8)	660 (26)

Case, Toilet Article
 Intended Use:
 Stateroom
 Manufacturer: **QUALITY METAL WORKS**
 SFC No. B-2A-1
 Hull Type Drawing No.
 No. S3601-1024899
 NSN: H2090-00-369-4566
 Principal Material: Aluminum
 Remarks: Three adjustable shelves and two toothbrushes racks. Bulkhead mounted.
 Mirror: two-ply polished plate safety glass.
 The mirror can be replaced, if necessary, by ordering Nation Stock No: H2090-00-355-4848.

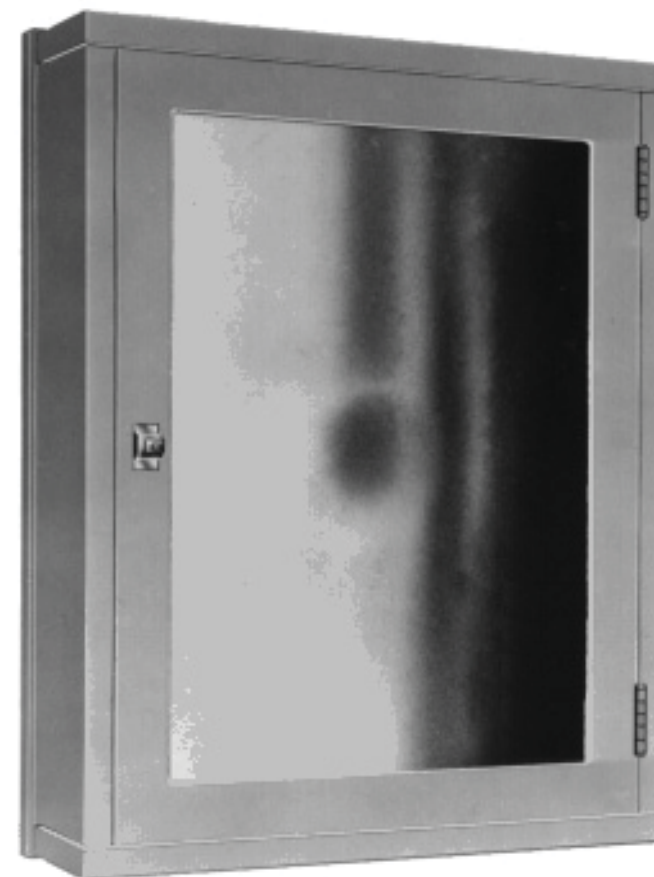

Lavatory Unit, Submarine

Item	Width	Depth	Height
Lavatory Unit, complete with sub-base, light, sink, and plumbing fixtures.	610 (24)	480 (19)	1910 (75)

Lavatory Unit
 Intended Use: In Officer Staterooms
 Manufacturer: **QUALITY METAL WORKS**
 SFC No. B-2A-2
 Hull Type Drawing No. No. 804-1623970
 NSN: 4510-01-142-1655

Principal Material:
 Nickel copper, aluminum, stainless steel sink bowl and top

Remarks:
 Upper cabinet is fitted with three adjustable shelves and two tooth brush racks. Two door cabinet below wash basin designed for soiled clothing also provides acces to plumbing.
 Lower doors are slot perforated for ventilation of cabinet.
 Unit includes fluorescent light, electric outlet, sink plumbing fixtures, and sub-base.



Lavatory Unit, Submarine

Width	Depth	Height
43(17)	210 (8-1/8)	1910 (75)

Lavatory Unit, Submarine

Intended Use:
 In Staterooms on Submarines
 Manufacturer: **QUALITY METAL WORKS**
 SFC No. B-2A-3

Hull Type Drawing No.
 No. 805-1629988

NSN: NONE

Principal Material:
 Aluminum, corrosion resistant steel

Remarks:
 Top cabinet-three shelves, adjustable in 1-inch increments.
 Center Cabinet-pivoted panel is the underside of a concealed wash basin.
 When unlatched and pivoted 90 degrees, the basin complete with faucets, soap dish, and drain assembly is ready for use.
 Bottom Cabinet-for soiled line and access to plumbing.
 Cabinets are integrated and secured upon installation.
 *Sub-base provided. (See Hull type Drawing No. S3306-921770).
 *Sub-base not included in these fingers.



Tables, Night, Types A & B

Item	Width	Depth	Height
Type A	510 (20)	440 (17-1/2)	840 (33)
Type B	510 (20)	440 (17-1/2)	840 (33)

Tables, Night, Types A & B

Intended Use:

In Cabin Saterooms

Manufacturer:QUALITY METAL WORKS

SFC No.

B-2A-4

Hull Type Drawing No.

No. 805-1749029

NSN: NONE

Principal Material: Aluminum, high pressure laminate

Remarks:

Two tier table.

Tops-high pressure plastic laminate top on each tier.
Type A has safe locker with three adjustable shelves.

Type B is without safe..

Sub-base provide.

ORDER OPTIONS:

Specify high pressure laminate manufacturer, color, and number.



Wardrobe, Long 24" Modular Furniture Unit No. 5

Width	Depth	Height
610 (24)	560 (22-1/8)	1830 (72)

Wardrobe, Long 24" Modular Furniture Unit No. 5

Intended Use:

In Staterooms

Manufacturer: QUALITY METAL WORKS

SFC No. B-2A-5

Hull Type Drawing No. No. 805-1622993

NSN: H2090-00-802-8314

Principal Material: Aluminum

Remarks:

Wardrobe has a clothes compressor.

Unit is furnished with a sub-base.

*Sub-base is not included in these figures (See Hull Type Drawing S3306-921770).

Order Options:



Wardrobe and File Section, 24" Modular Furniture Unit No. 12

Width	Depth	Height
610 (24)	560 (22-1/8)	1830 (72)*

Wardrobe and File Section, 24" Modular Furniture Unit No. 12

Intended Use: In Staterooms

Manufacturer: QUALITY METAL WORKS

SFC No. B-2A-6

Hull Type Drawing No. No. 805-1636403

NSN: H2090-00-591-9727

Principal Material: Aluminum

Remarks:

Wardrobe has a clothes compressor.

File drawer is sub-divided and is fitted with a file compressor. Includes lock.

Unit is furnished with a sub-base (See Hull Type Drawing No. S3306-921770).

*Sub-base is not included in these figures.

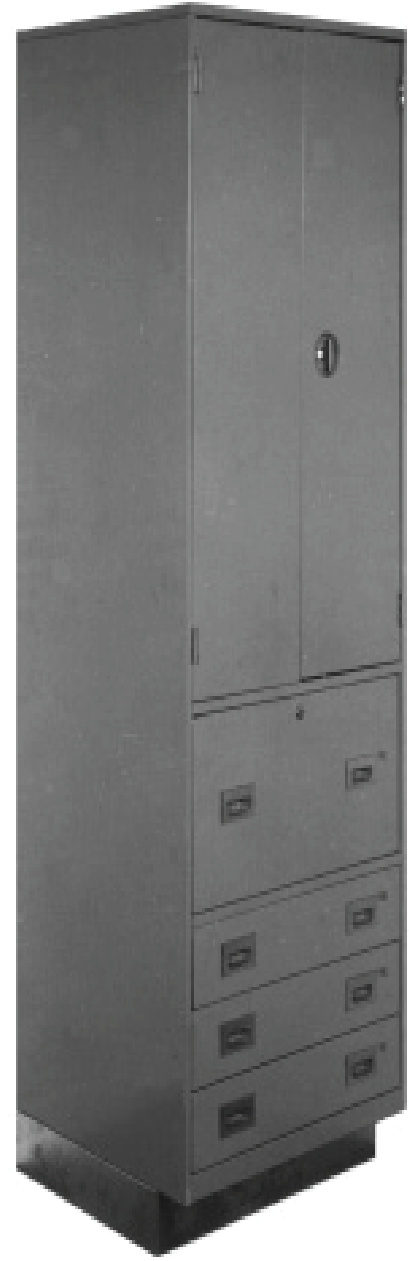

Wardrobe and File Section, 36" Modular Furniture Unit No. 13

Width	Depth	Height
910 (36)	560 (22-1/8)	1830 (72)*

Wardrobe and File Section, 36" Modular Furniture Unit No. 13

Intended Use:

In Staterooms

Manufacturer: QUALITY METAL WORKS

SFC No. B-2A-7

Hull Type Drawing No. No. 805-1636402

NSN: H2090-00-831-4084

Principal Material: aluminum

Remarks:

Short wardrobe has clothes compressor.

Two file drawers are fitted with compressors.

Each file drawers is furnished with a lock, keyed separately.

Unit is furnished with a sub-base (See Hull Type Drawing No. S3306-921770).

*Sub-base is not included in these figures.



Locker, Secretary and Drawer Section, 24" Modular Furniture Unit No. 14

Width	Depth	Height
610 (24)	560 (221/8)	1830 (72)*

Locker, Secretary and Drawer Section, 24" Modular Furniture Unit No. 14

Intended Use: In Staterooms
 Manufacturer: **QUALITY METAL WORKS**
 SFC No. B-2A-8

Hull Type Drawing No.
 No. 805-1636410

NSN:
 H2090-00-591-9719

Principal Material: Aluminum
 Remarks:

The vertical clear opening for the top locker is 12-3/4 inches.

The secretary unit is fitted with a fluorescent light, safe locker, and two pigeonholes

Locker has a book compressor unit at back of shelf.

Folding drop leaf can be locked to secure the secretary section.

Unit is furnished with a sub-base (See Hull type Drawing No. S3306-921770).

*Sub-base is not included in these figures.

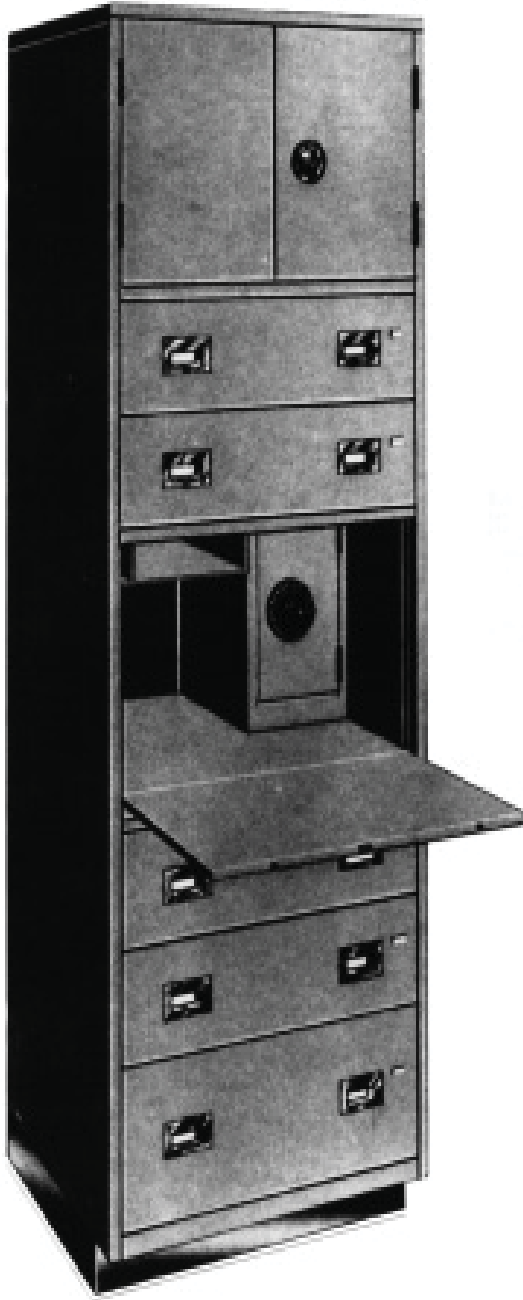

Locker, Secretary and Drawer Section, 36" Modular Furniture Unit No. 15

Width	Depth	Height
910 (36)	560 (22-1/8)	1830 (72)*

Locker, Secretary and Drawer Section, 36" Modular Furniture Unit No. 15

Intended Use: In Staterooms
 Manufacturer: **QUALITY METAL WORKS**

SFC No. B-2A-9

Hull Type Drawing No.
 No. 805-1637639

NSN:
 H2090-00-878-2205

Principal Material:
 Aluminum

Remarks:

Secretary unit has a fluorescent light, safe locker, and three pigeonholes.

Folding drop leaf can be locked to secure the secretary section.

Top locker has a book compressor at back of shelf.

Unit is furnished with a sub-base (See Hull Type Drawing No. S3306-921770).

*Sub-base is not included in these figures.



Drawer Locker Station, 36" Modular Furniture Unit No. 16

Width	Depth	Height
910 (36)	560 (22-1/8)	1830 (72)*

Drawer Locker Station, 36" Modular Furniture Unit No. 16

Intended Use: In Staterooms

Manufacturer: **QUALITY METAL WORKS**

SFC No. B-2A-10

Hull Type Drawing No.
No. 805-1637670

NSN: H2090-00-878-2206

Principal Material:
Aluminum

Remarks:

Locker has vertical clear opening of 13-3/4 inches and a book compressor.

Each lock keyed differently serves three drawers.

Unit furnished with sub-base (See Hull Type Drawing No. S3306-921770)

*Sub-base is not included in these figures.



Chest of Drawers

Width	Depth	Height
900 (35-1/4)	540 (21-1/8)	1360 (53-13/32)

Chest of Drawers

Intended Use:

In Staterooms or Senior Officer Quarters if Modular Units are not suitable

Manufacturer: **QUALITY METAL WORKS**

SFC No. B-2A-11

Hull Type Drawing No. No. S3306-630290

NSN: H2090-00-267-3434

Principal Material: Aluminum

Remarks:

Chest of Drawers can be used individually or with other units to form groups of furniture.

Basic unit can become a Chiffonnier by the addition of a 21" high locker unit stacked on top of the Chest of Drawers (See Hull Type Drawing S3306-630290).

Locker is fitted with one adjustable shelf and double swinging doors.

Chest of Drawers, when located in cabins or single staterooms, is to be fitted with a lock in the top drawer only; when located in double staterooms, is to be fitted with locks in top drawer and fourth drawer from top as shown in the photograph.

The locker is also detailed on the above referenced Hull Type Drawing.

Unit is furnished with a sub-base (See Hull Type Drawing No. S3306-921770).

*Sub-base is not included in these figures.



Wardrobes, Double with/without Drawer Section, 36" or 42"

Item	Width	Depth	Height
36" Unit with drawers	910 (36)	590 (23-1/4)	2150 (84-3/4)*
42" Unit with drawers	1070 (42)	590 (23-1/4)	2150 (84-3/4)*
Units without drawers			1930 (76)*

Wardrobes, Double with/without Drawer Section, 36" or 42"

Intended Use: In Staterooms if Modular Units are not suitable

Manufacturer: **QUALITY METAL WORKS**

SFC No. B-2A-12

Hull Type Drawing No. No. 805-1626412 (36)

NSN: None (36)

Principal Material: Aluminum

Remarks:

Wardrobes have hanging rod with clothes compressor.

Unit is furnished with a sub-base (See Hull Type Drawing No. S3306-921770).

*Sub-base is not included in these figures.



Wardrobe Units S1 and S2, Short Hanging, Submarine

Item	Width	Depth	Height
Unit S1	610 (24)	560 (22)	1220 (48)
Unit S2	460 (18)	560 (22)	1220 (48)

Wardrobe Units S1 and S2, Short Hanging, Submarine

Intended Use:

In Staterooms on Submarines

Manufacturer: **QUALITY METAL WORKS**

SFC No. B-2A-13

Hull Type Drawing No. No. 805-1646700
NSN: NONE

Principal Material: Aluminum

Remarks:

Units have clothes compressor and hat shelf.

Knock down construction for shipping through a 25" dia hatch.

Unit is generally used with Drawer Unit, S6, S7, S8 or S9, of Hull Type Drawing 805-1648290 as shown in photograph.

Finish-baked enamel or decorative factory bonded vinyl film.



Wardrobe Units S3 and S4, Long Hanging, Submarine

Item	Width	Depth	Height
Unit S3	610 (24)	560 (22)	1830 (72)*
Unit S4	460 (18)	560 (22)	1830 (72)*

Wardrobe Units S3 and S4, Long Hanging, Submarine

Intended Use:
In staterooms on Submarines
Manufacturer: **QUALITY METAL WORKS**

SFC No. B-2A-14
Hull Type Drawing No.
No. 805-1646701
NSN: NONE

Principal Material: Aluminum
Remarks:

Units have clothes compressor, hat shelf, and hanging rod.

Knockdown construction to permit access through a 25" diameter hatch.

Finish-baked enamel.

Sub-base provided (See Hull type Drawing No. S3306-921770)

*Sub-base not included in these figures.

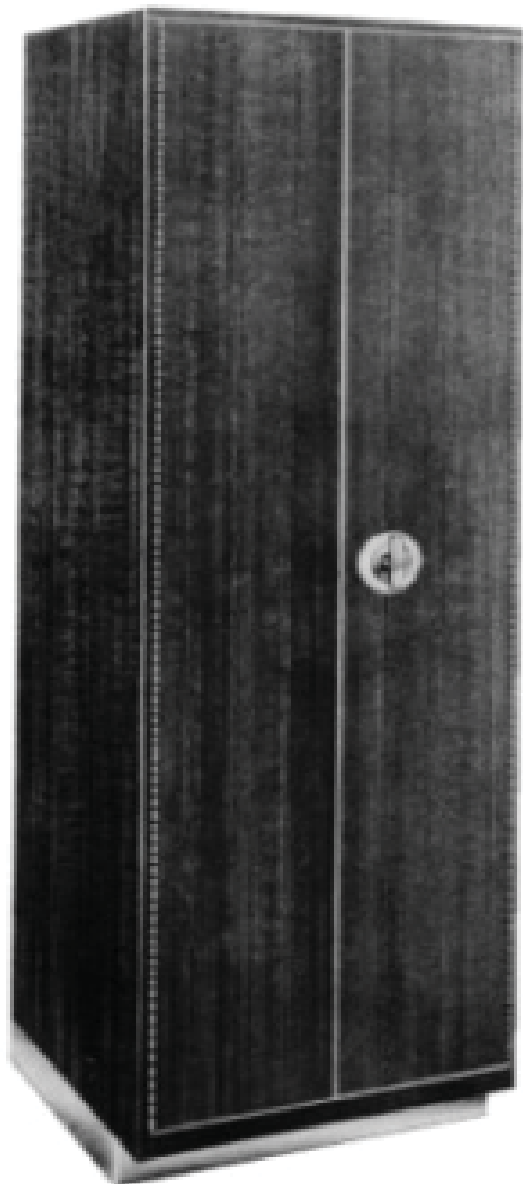

Secretary Bureau Unit S5, Submarine

Item	Width	Depth	Height
With Safe Locker	690 (27)	440 (17-1/4)	1060 (41-7/8)*
Without Safe Locker	690 (27)	440 (17-1/4)	1060 (41-7/8)*

Secretary Bureau Unit S5, Submarine

Intended Use: In Staterooms on Submarines
Manufacturer: **QUALITY METAL WORKS**

SFC No. B-2A-15
Hull Type Drawing No. 805-1640931
NSN: NONE
Principal Material:

Aluminum, high pressure laminate
Remarks:

A safe locker is installed inside the Secretary Bureau unless otherwise specified.

Generally used in conjunction with utility locker, Unit S-10 as shown on Hull Type Drawing 805-1648290.

Knockdown construction for access through 25-inch hatch.

Drawer stowage capacity-3.75 cu. ft. Fluorescent lamp to illuminate writing surface.

Sub-base provided. (See Hull Type Drawing No. S3306-921770).

*Sub-base is not included in these figures.

ORDER OPTIONS:

Finish, front surface-high pressure laminate or paint.
Finish-specify high pressure laminate manufacturer, color, and number for writing surface.

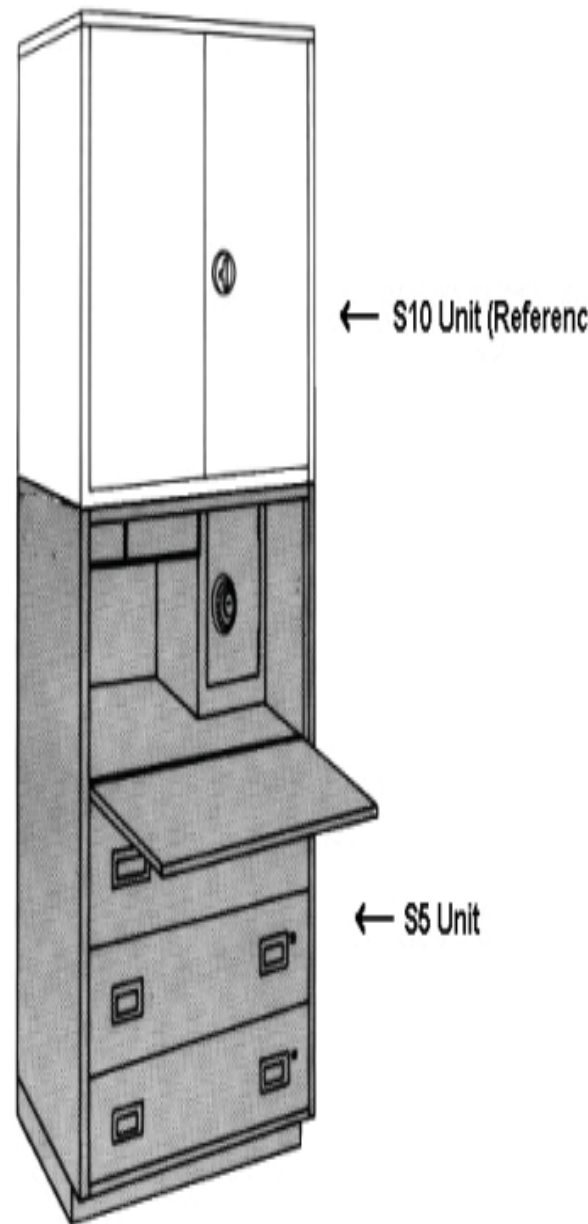

Drawer Units S6, S7, S8, and S9 submarine

Item	Width	Depth	Height
Unit S6-3 drawer	610 (24)	560 (22)	610 (24)
(shown)	460 (18)	560 (22)	610 (24)
Unit S7-3 drawer	610 (24)	560 (22)	430 (17-1/8)
Unit S8-2 drawer	460 (18)	560 (22)	430 (17-1/8)

Locker Units S10, S11, and S12 Utility, Submarine

Item	Width	Depth	Height
Unit S10	690 (27)	440 (17-1/4)	780 (30-7/8)
Unit S11 (shown)	610 (24)	560 (22)	780 (30-7/8)
Unit S12 (single door)	460 (18)	560 (22)	780 (30-7/8)

Drawer Units S6, S7, S8, and S9 submarine

Intended Use:
In Staterooms on Submarines
Manufacturer: **QUALITY METAL WORKS**
SFC No. B-2A-16

Hull Type Drawing No.
No. 805-1641662

NSN:
NONE

Principal Material:
Aluminum

Remarks:

Generally used in conjunction with Utility Locker. Unit S-10, S-11, or S-12 short Wardrobe, Unit S-1 or S-2, as shown on Hull Type Drawing 805-1648290.

Knockdown construction for shipping through a 25-inch diameter hatch. If used independently, each unit must have false top.

Sub-bases are provided for Unit S-6 and S-7. (See Hull Type Drawing No. S3306-921770).

*Sub-base is not included in these figures.



← S1 or S2 Units Shown or S10 - S12 Units (Reference)

← S6 - S9 Units

Locker Units S10, S11, and S12 Utility, Submarine

Intended Use:
In staterooms on Submarine
Manufacturer: **QUALITY METAL WORKS**
SFC No. B-2A-17
Hull Type Drawing No. No. 805-1648289
NSN: NONE

Principal Material:
Aluminum

Remarks:

Generally used with Drawer Unit, S-6, S-7, S-8, or S-9, or Secretary Unit, Unit S-5, as shown on Hull Type drawing 805-1648290.

2 adjustable shelves.

Book compressor on locker bottom.

Knockdown construction to permit access through a 25-inch diameter hatch.

Finish-baked enamel.



← S10 - S12 Units

← S6 - S9 Units (Reference)

Width	Depth	Height
500 (19-3/4)	20 (7/8)	1420 (55-3/4)

Width	Depth	Height
330 (13-1/8)	30 (1-1/8)	430 (17-1/8)

Mirror, Full Length, Bulkhead Mounted

Intended Use: In Berthing Spaces
 Manufacturer: **QUALITY METAL WORKS**

SFC No. B-2B-1

Hull Type Drawing No.
 No. 804-4623537

NSN:
 None

Principal Material:
 Anodized aluminum, laminated glass, and high pressure laminate

Remarks:
 Snap-in cover strip on frame may be color-anodized aluminum or high pressure laminated plastic. Specify finish and color.
 If mirror is to be mounted on a structural aluminum bulkhead, furring pieces are supplied which are welded to the bulkhead for attachment of the mirror.

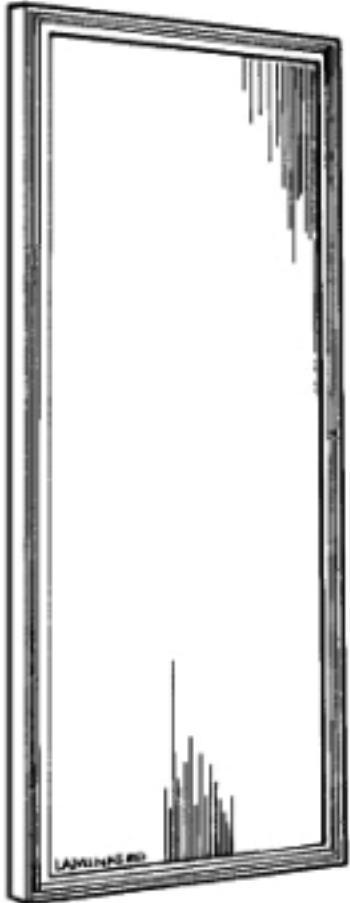

Mirror, Mounted, Shock - hardened

Intended Use:
 Primarily in Berthing and Sanitary Spaces
 Manufacturer: **QUALITY METAL WORKS**

SFC No. B-2B-2

Hull Type Drawing No.
 No. 805-2253852

NSN:
 7105-00-267-2001

Principal Material:
 Stainless steel, and laminated polish plate glass

Remarks:
 Glass.
 Stainless steel frame.
 Bulkhead mounted.



Container, Stowage, For Emergency Escape Breathing Device (EEBD)

Width	Depth	Height
250 (10)	260 (10-1/4)	140 (5-3/8)

Container, Stowage, For Emergency Escape Breathing Device (EEBD)

Intended Use: Various Locations

Manufacturer: **QUALITY METAL WORKS**

SFC No. B-2B-4

Hull Type Drawing No. No. 804-5751208

NSN:

Principal Material:

Aluminum

Remarks:

This container provides convenient stowage and rapid access to individual emergency escape breathing devices located over each berth pan in enlisted personnel berthing spaces.

The container is designed to stow one EEBD.

EEBD container is used throughout the ship as required.

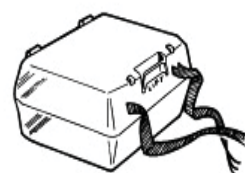
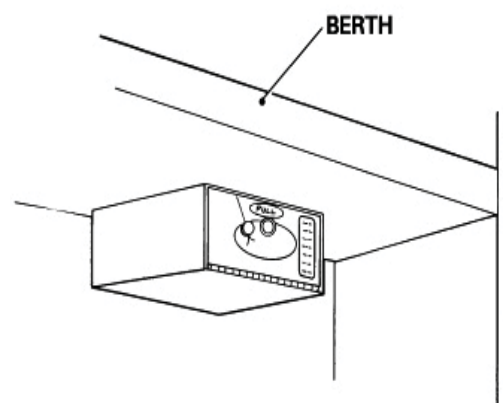

Emergency Escape Breathing Device

Lockers, Soiled Clothes

Item	Width	Depth	Height
Type I	610 (24)	610 (24)	1830 (72)
Type II	910 (36)	610 (24)	1830 (72)
Type III (shown)	1220 (48)	610 (24)	1830 (72)
Type IV	1520 (60)	610 (24)	1830 (72)
Type V	1830 (72)	610 (24)	1830 (72)

Lockers, Soiled Clothes

Intended Use:

In CPO, Crew and Marine Berthing Spaces

Manufacturer: **QUALITY METAL WORKS**

SFC No. B-2B-5

Hull Type Drawing No. No. 805-1648667

NSN: NONE

Principal Material: Aluminum

Remarks:

All doors louvered.

Types I & II have single upper and lower door.

Types III, IV & V have double doors.

Upper doors fitted with spring hinges.

Provide a minimum of .75 cubic feet per man and at least two compartment per berthing space, one for whites, one for blues.

One half of each locker shall be labeled for soiled whites and the other for soiled blues.

Where a type III, IV, or V is required, two of type I or II, as appropriate, may be used.

Where two lockers are provided in one space, the partition plate may be omitted and one locker labeled for soiled whites and the other for soiled blues. All lockers to be mounted on legs furnished with the locker.

Locker is assembled with screws and nuts.

ORDER OPTIONS:

Specify assembled or KD.



Locker, Clothes, Type A

Width	Depth	Height
560 (22)	380 (15)	1910 (75)

Locker, Clothes, Type A
 Intended Use:
 In CPO Berthing Spaces for Individual Use
 Manufacturer: **QUALITY METAL WORKS**

SFC No.
 B-2B-6
 Hull Type Drawing No.
 No. 805-1626365
 NSN:
 H2090-00-543-3596

Principal Material:
 Aluminum

Remarks:
 Removable bottom to permit deck inspection.
 Door can be padlocked, but padlock is not provided.



Lockers, Overcoat, Types E and F and, Uniform, types G and H, CPO and Marine

Item	Width	Depth	Height
Overcoat Locker Type E (shown)	1000 (39-1/2)	640 (25)	1840 *(72-1/4)
Overcoat Locker Type F	690 (27)	640 (25)	1840 *(72-1/4)
Uniform Locker Type G (shown)	1000 (39-1/2)	640 (25)	2060* (81-1/4)
Uniform Locker Type H	690 (27)	640 (25)	2060* (81-1/4)

Lockers, Overcoat, Types E and F and, Uniform, types G and H, CPO and Marine

Intended Use:
 In CPO and Marine Berthing Spaces
 Manufacturer: **QUALITY METAL WORKS**

SFC No. B-2B-7
 Hull Type Drawing No. No. S3306-921757

NSN:
 NONE

Principal Material:
 Aluminum

Remarks:
 Lockers are fitted with hanging rods and clothes compressors.
 Door can be padlocked, but padlocks not provided.

*Sub-base not included in size description.

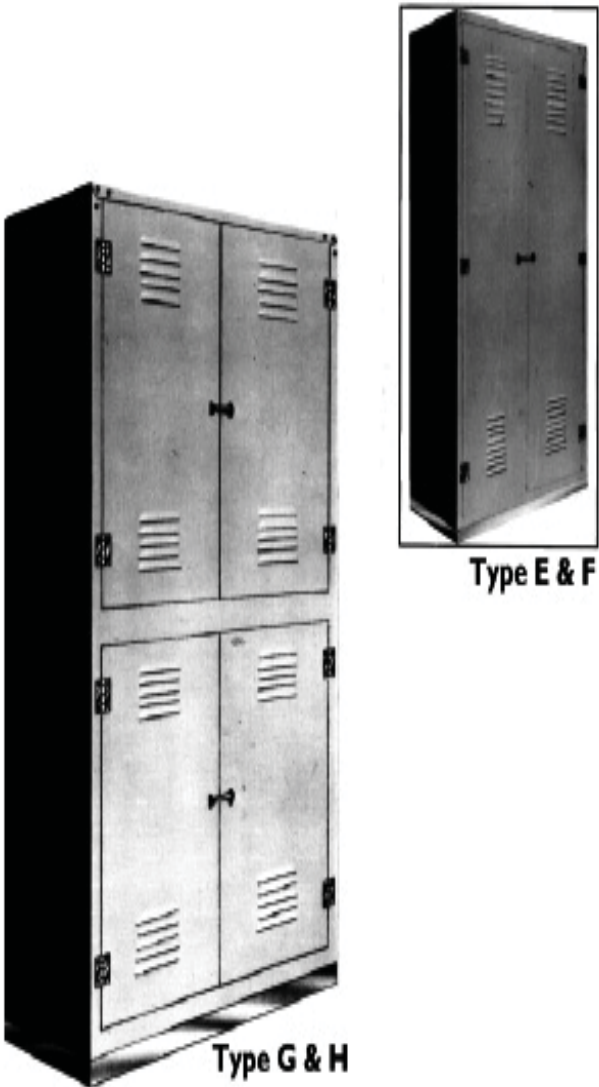

Lockers, Clothes, Type B-1, Crew

	NSN	Width	Depth	Height
Left Hand Door (shown)	H2090-00-543-3595	660 (26)	510 (20)	39.9 (88)
Right Hand Door	H2090-00-543-3594	660 (26)	510 (20)	39.9 (88)

Lockers, Clothes, Type B-1, Crew

Intended Use:
In Crew Berthing spaces when Underberth Stowage is not Available

Manufacturer: **QUALITY METAL WORKS**

SFC No. B-2B-8

Hull Type Drawing No. 805-1626432

NSN:

Principal Material: Aluminum

Remarks:

All lockers are compartmented as per the lower unit.

Locker can be ordered with either a right or left hand door swing.

Door can be padlocked, but paklock not provided.

Three-high unit.



Lockers, Crew, Type B-2, Clothes

	NSN	Width	Depth	Height
Right Hand Unit	H2090-00-543-3592	440 (17-1/2)	510 (20)	1910* (75)
Left Hand Unit	H2090-00-543-3593	440 (17-1/2)	510 (20)	1910* (75)

Lockers, Crew, Type B-2, Clothes

Intended Use:
In Crew Berthing Area when Underberth Stowage is not Available
Manufacturer: **QUALITY METAL WORKS**
SFC No. B-2B-9

Hull Type Drawing No.
No. 805-1626432

NSN: See Below

Principal Material: Aluminum

Remarks:

Provides 7-1/2 cubic feet stowage for each of 2 crew-members.

Upper locker is identical to the lower.

Locker can be fitted with either left or right hand door swing.

Doors lockable with padlock, but padlock is not provided.

Removable bottom for deck maintenance.

*Two-high unit.



Locker, Clothes, Marines

Width	Depth	Height
530 (21)	560 (22)	2060 (81)

Locker, Clothes, Marines

Intended Use:
In Marine Berthing Spaces for Individual Use

Manufacturer: **QUALITY METAL WORKS**

SFC No. B-2B-10

Hull Type Drawing No. No. 805-1629990

NSN: None

Principal Material:
Aluminum

Remarks:

Locker provides long and short hanging and folded clothes stowage.

Locker is compartmented to accommodate all individual's uniforms and long coats.

Door can be padlocked, but padlock not provided.



Locker, Clothes, Troop

Width	Depth	Height
560 (22)	460 (18)	1910 (75)

Locker, Clothes, Troop

Intended Use:
In Troop Berthing Areas

Manufacturer: **QUALITY METAL WORKS**

SFC No. B-2B-11

Hull Type Drawing No. No. 805-1630725

NSN: None

Principal Material:
Aluminum

Remarks:

All lockers compartmented as per the lower locker.

Bottom of the lower locker locker is removable for deck inspection.

Door can be padlocked, but padlock is not provided.

Provides 4.1 cubic feet of stowage/locker for each of 4 troops.



Locker, Clothing

Locker, CLOthing (cont'd)

Product	Width	Depth	Height
Type 1 Locker	460 (18)	560 (22)	1910 (75)
Type 2 Locker	910 (36)	560 (22)	1910 (75)
Type 3 Locker	460 (18)	560 (22)	1910 (75)
Type 4 Locker	460 (18)	560 (22)	1910 (75)
Type 5 Locker	460 (18)	560 (22)	930 (36-1/2)
Type 6 Locker	460 (18)	560 (22)	1910 (75)

Product	Width	Depth	Height
Type 7 Locker	640 (25)	560 (22)	1910 (75)
Type 8 Locker	460 (18)	560 (22)	1910 (75)
Type 9 Locker	250 (10)	560 (22)	1910 (75)
Type 10 Locker	910 (36)	560 (22)	1910 (75)
Type 11 Locker	460 (18)	560 (22)	1910 (75)
Type 12 Locker	610 (24)	560 (22)	1910 (75)

Locker, Clothing

Intended Use:
In Living Spaces

Manufacturer: **QUALITY METAL WORKS**

SFC No. B-2B-13 1 OF 2

Hull Type Drawing No. No. 803-6397307

NSN: None

Principal Material: Aluminum

Remarks:

All lockers have louvers in doors for air ventilation.

Sub-base inxlusws with all lockers, except type 9.

Doors lockable with padlock, but padlock not included.

ORDER OPTIONS

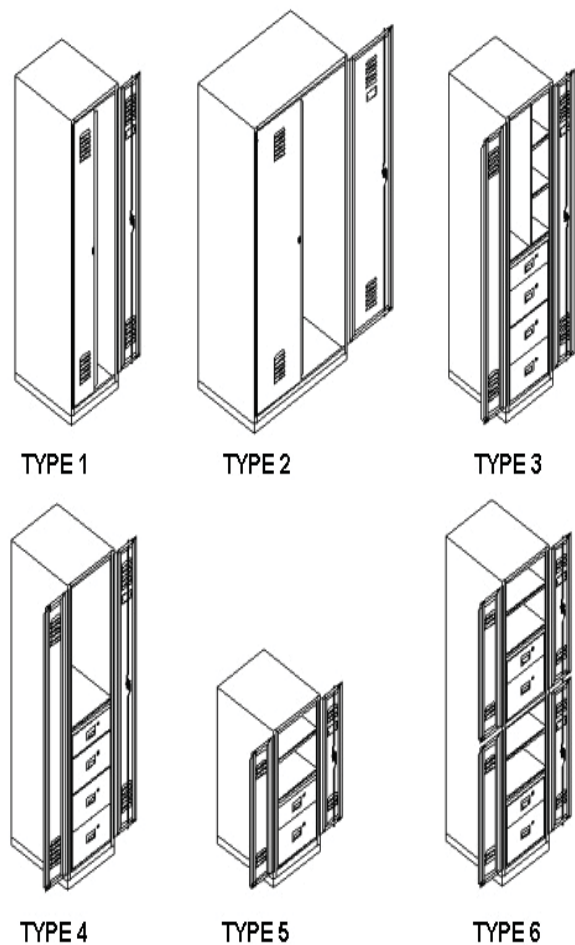

Locker, CLOthing (cont'd)

Intended Use:

In Living Spaces

Manufacturer: **QUALITY METAL WORKS**

SFC No. B-2B-13 2 of 2

Hull Type Drawing No. 803-6397307

NSN: NONE

Principal Material: Aluminum

Remarks:

All lockers have louvers in doors for air ventilation.

Sub-base included with all lockers, except type 9.

Doors lockable with padlock, but padlock not included.

Sub-base for type 9 ordered as needed.

ORDER OPTIONS:

Locker type and quantity.

Multiple unit sub-base.

Sub-base for type 9 locker.

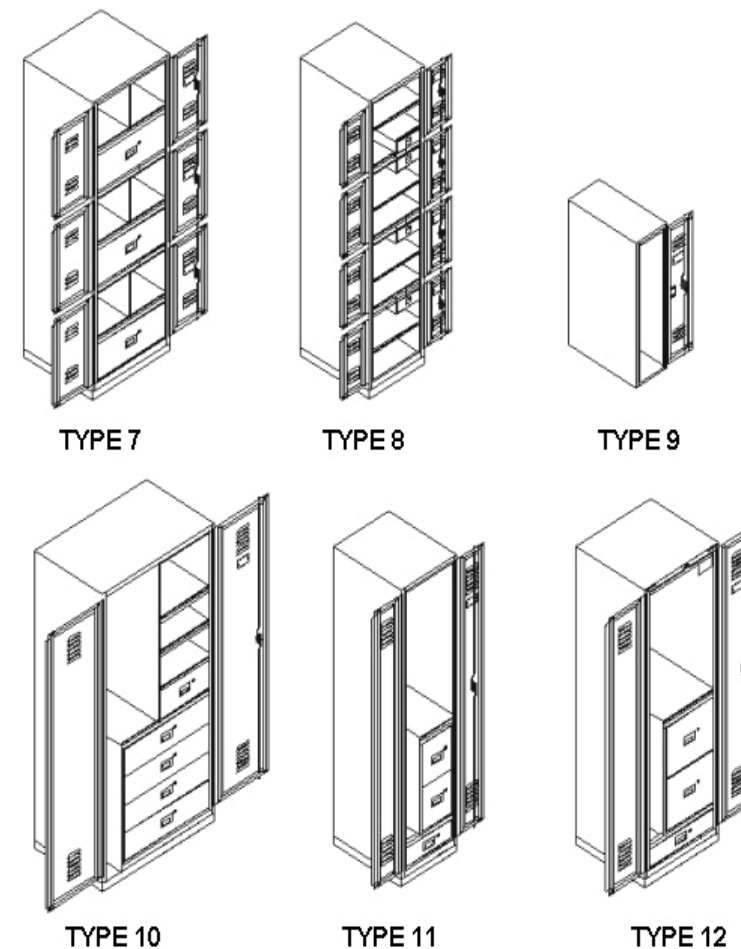

Transom Seats, Type I Through VI, Crew Submarine

Item	Length	Depth	Height
2 Man Transom	1220 (48)	530 (21)	890 (35)
3 Man Transom (shown)	1830 (72)	530 (21)	890 (35)

Transom Seats, Type I Through VI, Crew Submarine
Intended Use: In Submarine Crew Mess Area

Manufacturer: **QUALITY METAL WORKS**

SFC No. B-3A-19
Hull Type Drawing No. No. 805-1644752
NSN: NONE
Principal Material: Aluminum, corrosion resisant steel, cushioning, and vinyl
Remarks:
Can be ordered with 2 or 3 seats and with or without drawers.
Type I (R), drawer in right hand end & lockers with hinged seat pan for 3 men.
Type I (L), drawer in left hand end & lockers with hinged seat pan for 3 men.
Type II, 3 lockers with hinged seat pan for 3 men.
Type III, drawer in both ends & locker with hinged seat pan for 3 men.
Type IV (R), drawer in right hand end & locker with hinged seat pan for 2 men.
Type IV (L), drawer in left hand end & locker with hinged seat pan for 2 men.
Type V, 2 lockers with hinged seat pan for 2 men.
Type IV, drawer in both ends for 2 men.
See Hull Type drawing for variable arrangements and style sof similar types.

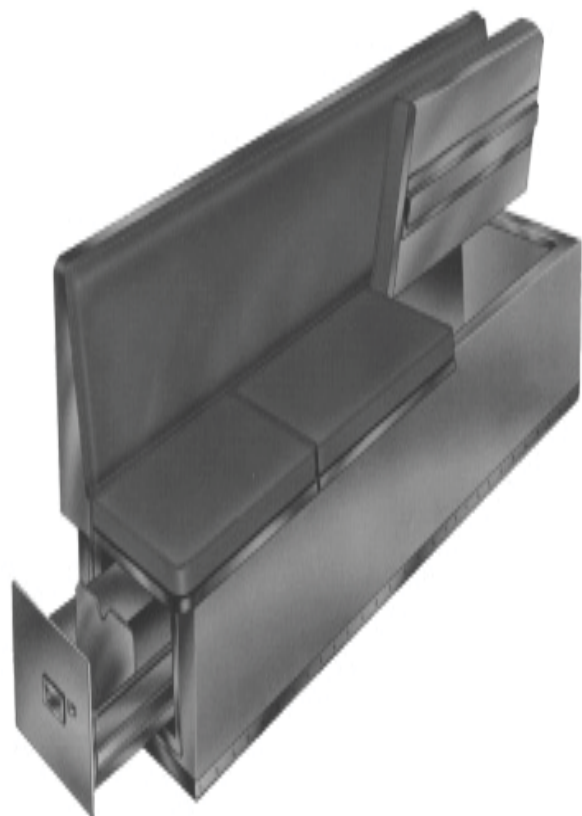

Booths, Mess, Single & Double

Item	Width	Depth	Height
Type A - Double	1220 (48)	1220 (48)	910 (36)
Type B - Single	1220 (48)	610 (24)	910 (36)
Type C - Double	610 (24)	1220 (48)	910 (36)
Type D - Single	610 (24)	610 (24)	910 (36)

Booths, Mess, Single & Double

Intended Use: Mess Rooms
Manufacturer: **QUALITY METAL WORKS**

SFC No. B-3E-1

Hull Type Drawing No. No. 805-4661742

NSN: NONE

Principal Material:
Aluminum, upholstery, and cushioning

Remarks:

Adjustable sub-base with stainless steel coving can l fitted to each unit.

Cushions are easily removed for cleaning or repair

ORDER OPTIONS:

Upholstery - vinyl or woven fabric.

Upholstery - color and pattern.

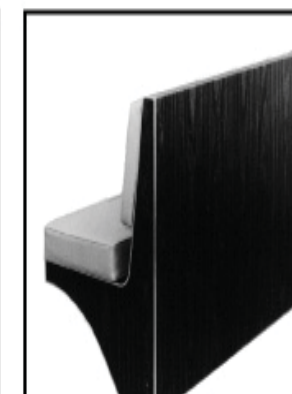

Bench with Stowage Under

Item	Length	Depth	Height
2-Seat Unit	1020 (40-1/4)	640 (25)	860 (34)
3-Seat Unit	1540 (60-1/2)	640 (25)	860 (34)

Bench with Stowage Under

Intended Use: In Flight Deck Shelters

Manufacturer: **QUALITY METAL WORKS**

SFC No.
B-3F-1

Hull Type Drawing No.
805-2217400

NSN:
NONE

Principal Material:
Steel frame, upholstery, and cushioning

Remarks:

Seats fold up and backs of seats fold down for full access to stowage spaces.

ORDER OPTIONS:

Vinyl color

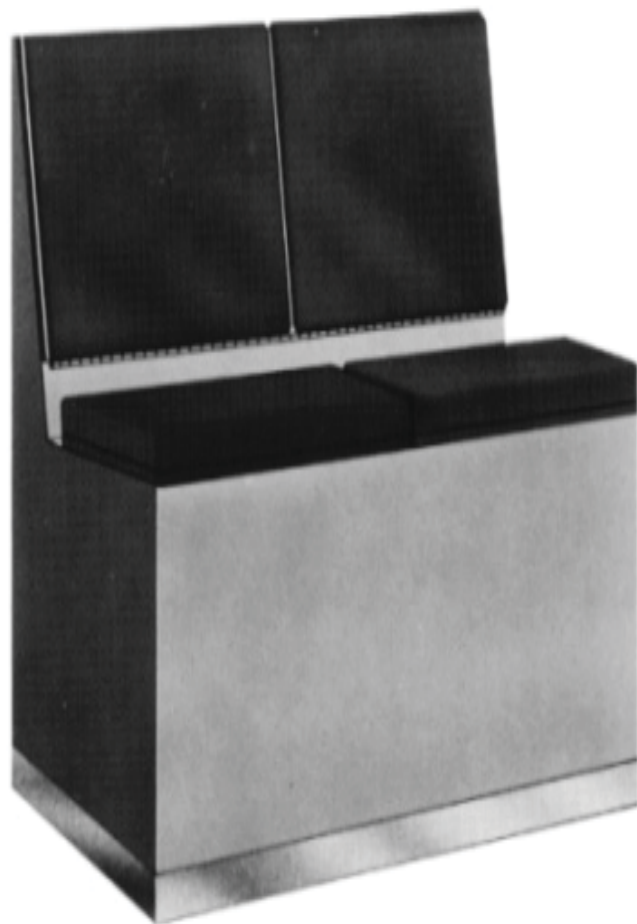

Benches with Stowage Under, Padded

Item	Length	Depth	Height
Type A	910 (36)	410 (16)	510 (20)
Type B	910 (36)	410 (16)	510 (20)
Type C (shown)	910 (36)	410 (16)	510 (20)

Benches with Stowage Under, Padded

Intended Use:
Multipurpose Tool Stowage and Seating

Manufacturer: **QUALITY METAL WORKS**

SFC No. B-3F-2

Hull Type Drawing No. 805-1634565

NSN: NONE

Principal Material:
Aluminum, upholstery, and cushioning

Remarks:

Type A is a chest with hinged seat.

Type B has four drawers with fixed seat.

Type C has shallow chest and hinged seat.

ORDER OPTIONS:

Vinyl upholstery - color



Sideboards and Serving Tables, Modular

Basic Units	NSN	Length	Width	Height
Unit No. 1 with top and base (shown in inset photo)	H2090-00-638-0049	610 (24)	480 (19)	970 (38)
Unit No. 2 with top and base.	H2090-00-638-1168	610 (24)	480 (19)	970 (38)
Top for 1 Unit	H2090-00-638-1169	660 (26)	480 (19)	
Top for 2 Units	H2090-00-638-1172	1270 (50)	480 (19)	
Top for 3 Units	H2090-00-638-1443			

Sideboards and Serving Tables, Modular

Intended Use:

In Officer Wardroom

Manufacturer: **QUALITY METAL WORKS**

SFC No. B-4A-1

Hull Type Drawing No. No. 805-1625029

NSN: See Below

Principal Material: Aluminum and high pressure laminate.

Remarks:

Units may be arranged in single or multiple units to suit shipboard arrangement to make up a sideboard of serving table.

4" splash integral with top.

Unit No. 1 (small photograph) fitted with one adjustable shelf.

Drawer has one tray and one condiment retainer.

Unit No. 2, shown in the center of multiple assembly, has a tray in each of the samll drawers.

See Hull Type Drawing for alternate arrangements.

ORDER OPTIONS

Specify high pressure laminate manufacturer, color



Table, Dining, Round top

Item	Dia	Height
Table, Dining, Round top	1220 (48)	770 (30-1/2)

Table, Dining, Round top

Intended Use:

In Senior Officer Quarters

Manufacturer: **QUALITY METAL WORKS**

SFC No. B-4A-2

Hull Type Drawing No. No. 805-2217401

NSN: NONE

Principal Material:

Aluminum, corrosion resistant steel and high pressure laminate.

Remarks:

Design matches cabin extension table, Hull type D

rawing No. S3302-631493 and round coffee table, Hull Type Drawing No. 805-2217419.

ORDER OPTIONS

Specify high pressure laminate manufacturer, color and number.



Table, Dining, Portable

Length	Width	Height
2340 (92)	10 (32)	780 (30-1/2)

Table, Dining, Portable

Intended Use: Officer's Quarters

Manufacturer: **QUALITY METAL WORKS**

SFC No. B-4A-3

Hull Type Drawing No. No. 805-2214471

NSN: NONE

Principal Material:
Aluminum and high pressure laminate

Remarks:

Exterior Finish: High pressure plastic laminate.

Folding legs.

Lee rails not provided.

*Other sizes fabricated to order.

ORDER OPTIONS

Specify high pressure laminate manufacturer, color and number.

Order Options:

Specify high pressure laminate manufacturer, color, and number.



Table, Dining/Coffee, Adjustable Height

Item	SFC No.	Dia.	Height
Table, "Hi Lo"	B-4A-4	910 (36)	460-740 (18-29)

Table, Dining/Coffee, Adjustable Height

Intended Use:
In Senior Officer Cabins

Manufacturer: **QUALITY METAL WORKS**

SFC No. B-4A-4

Hull Type Drawing No. NONE

NSN: NONE

Principal Material:
Aluminum frame and high pressure plastic laminate.

Remarks:

Table can be adjusted from coffee table height to dining table height.

Available in sizes up to 48 inches in diameter.

Stainless steel metal edging flush with table top.

ORDER OPTIONS:

Leg/Column Base - brushed aluminum or paint color.

Specify high pressure laminate manufacturer, color,



Tables, Mess, Portable, Lightweight, Crew

Item	Length	Width	Height
4-Man Table	1170 (46)	690 (27)	740 (29)
6-Man Table	1750 (69)	690 (27)	740 (29)

Tables, Mess, Portable, Lightweight, Crew

Intended Use:

Mess Decks with Dual Usage (e.g., Weapons Assembly)

Manufacturer: **QUALITY METAL WORKS**

SFC No. B-4B-1

Hull Type Drawing No.

No. 804-4661738 & 804-4661739

NSN: NONE

Principal Material:

Aluminum, high pressure laminate

Remarks:

The two sizes of tables are identical in design except for folding mechanism of "gate" legs.

Both tables have two folding gate legs but those of the 4-man table telescope so as to fit neatly beneath and within periphery of tabletop.

A positive locking device is incorporated to maintain gate legs in open position. A securing lever is provided to lock gate legs in their closed position for stowage.

Tables are stackable without damage to each other to whatever height is convenient for handling. When tables are stacked care should be taken that they are adequately secured.

Tops - high pressure plastic laminate with stainless steel edge binding flush with table top.

Gate legs contain a decorative accent panel which can be matched or coordinated with design and color of top.

Glides - although not indicated on Hull type Drawing adjustable nylon glides should be ordered to compensate for deck irregularity.

Tables shorter than 46" length cannot be fabricated to match, due to nature of design.

For such sizes, pedestal tables are recommended. (See Hull-Type Drawing 804-4623536).



Table, Mess, Crew

Item	SFC No.	Length	Width	Height
Mess Table	B-4B-2a	610 (24)	690 (27)	760 (30)
	B-4B-2b	1070 (42)	690 (27)	760 (30)
	B-4B-2c	1170 (46)	690 (27)	760 (30)
	B-4B-2d	1220 (48)	690 (27)	760 (30)
	B-4B-2e*	1370 (54)	690 (27)	760 (30)
	B-4B-2f	520 (60)	690 (27)	760 (30)

Table, Mess, Crew

Intended Use:

In Mess Areas Suitable for use in Conjunction with Booth or Portable Seating

Manufacturer: **QUALITY METAL WORKS**

SFC No. B-4B-2

Hull Type Drawing No. No. NONE

NSN:

Principal Material:

Aluminum, high pressure laminate

Remarks:

ORDER OPTIONS:

Lee rails are optional.

Ordering activity to specify:

Top - high pressure laminate manufacturer, color, and number



Mess Table w/Swivel Seats

Item	Length	Width	Height
4-Man Table (Type A)	1520 (60)	1070 (42)	760 (30)
4-Man Seat & Booth (Type B)	1100 (43-1/2)	1070 (42)	760 (30)
4-Man Transom Booth (Type D)			
2-Man Table (Type C)	840 (33)	1070 (42)	760 (30)
2-Man Table (Type E)	610 (24)	1520 (60)	760 (30)

Mess Table w/Swivel Seats

Intended Use: In Crew Mess Areas

Manufacturer: **QUALITY METAL WORKS**

SFC No. B-4B-4

Hull Type Drawing No.

No. LBNS Type 612-4833273

NSN: No. NONE

Principal Material:

Steel, aluminum, and high pressure laminate

Remarks:

Lee railing are optional. Ordering activity to specify.

Seat shall be cast aluminum with a baked enamel finish. Or-

dering activity to specify color.

For the selection of High Pressure Plastic Laminate specify

brand, color, and texture.

Stainless steel table top edge binding.

ORDER OPTIONS:

Frame and seat - colors.

Top - high pressure laminate manufacturer, color, and num-

ber.

Additional sizes available.



Table, End

Item	SFC No.	Length	Width	Height
Rectangular End Table	B-4C-12a	740 (29)	510 (20)	570 (22-1/2)
Curved End Table	B-4C-12b	740 (29)	510 (20)	570 (22-1/2)

Table, End

Intended Use:

In Senior Officer Quarters

Manufacturer: **QUALITY METAL WORKS**

SFC No. B-4C-1

Hull Type Drawing No.

No. 805-2224396 - Rectangular End Table, 805-

2224395 - Curved End Table

NSN: NONE

Principal Material:

Aluminum frame and high pressure laminate

Remarks:

Legs adjustable for sheer and camber.

Cowling: Polished aluminum.

ORDER OPTIONS:

Specify high pressure laminate manufacturer, color, and number.

Custom sizes available.

Matches coffee tables B-4C-8.



Tables, Lounge

Item	SFC No.	Length	Width	Height
Coffee Table (shown)	B-4C-2a	1070 (42)	460 (18)	22.7 (50)
End Table (shown)	B-4C-2b	610 (24)	460 (18)	18.1 (40)
Corner Table	B-4C-2c	760 (30)	760 (30)	22.7 (50)
End Table	B-4C-2d	690 (27)	690 (27)	18.1 (40)
Coffe Table	B-4C-2e	1520 (60)	610 (24)	27.2 (60)
Coffe Table	B-4C-2f		910 (36" dia.)	24.9 (55)

Tables, Lounge
 Intended Use: In Wardroom Lounges and Cabins
 Manufacturer: **QUALITY METAL WORKS**

SFC No. B-4C-2

Hull Type Drawing No.
 No. NONE

NSN:
 NONE

Principal Material:
 Aluminum frame and high pressure plastic laminate finish

Remarks:

ORDER OPTIONS:

Top - high pressure laminate manufacturer, color, and number.

Legs and Frame - brushed aluminum or paint (color).



Tables, Lounge

Item	SFC No.	Length	Width	Height
Table, cube, end	B-4C-3a	530 (21)	460 (18)	560 (22)
Table, cube, corner	B-4C-3b	610 (24)	610 (24)	560 (22)

Tables, Lounge

Intended Use:
 In Officer Lounges and Cabins

Manufacturer: **QUALITY METAL WORKS**
 Turnbull Enterprises, Inc.

Alternate Source:
 See Sources for Shipboard Furniture link.

SFC No.
 B-4C-3

Hull Type Drawing No.
 No. NONE

NSN:
 NONE

Principal Material:
 Aluminum frame and high pressure laminate finish

Remarks:

ORDER OPTIONS:

Specify high pressure laminate manufacturer, color, and number.

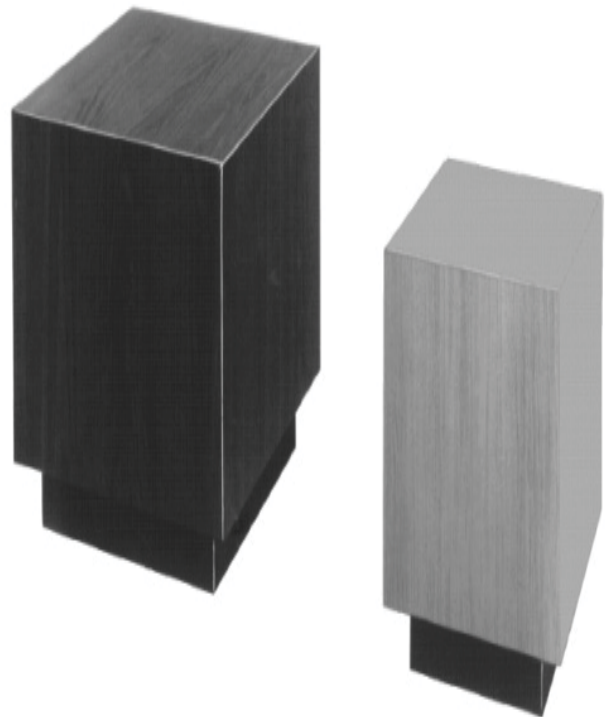

Tables, Lounge

Tables, Lounge

Item	SFC No.	Length	Width	Height
Table, coffee	B-4C-5a	760 (30) dia		460 (16)
Table, coffee	B-4C-5b	1220 (48)	460 (18)	460 (16)
Table, end	B-4C-5c	690 (27)	460 (18)	610 (24)

Item	SFC No.	Length	Width	Height
Table, side	B-4C-4a	530 (21)	300 (12)	410 (16)
Table, lamp	B-4C-4b	610 (24)	610 (24)	560 (22)

Tables, Lounge
 Intended Use: In Wardroom Lounges and Cabins
 Manufacturer: **QUALITY METAL WORKS**

Tables, Lounge
 Intended Use:
 In Lounges and Cabins

Manufacturer: **QUALITY METAL WORKS**
 SFC No. B-4C-4

Hull Type Drawing No. No. NONE

NSN: NONE

SFC No. B-4C-5

Hull Type Drawing No. No. NONE

NSN: NONE

Principal Material:
 Aluminum frame and top, and high pressure laminate top

Principal Material:
 Aluminum frame and top, and high pressure plastic laminate

Remarks:

Remarks:

Stainless steel metal edging flush with table top.

Stainless steel metal edging flush top surface.

ORDER OPTIONS:

ORDER OPTIONS:

Legs, frames and lee rails - brushed aluminum or paint (color).

Legs and frame - brushed aluminum or paint (color).

Specify high pressure laminate manufacturer, color, and number.

Custom sizes available.

Specify lee rails if needed.

Custom sizes available.

Specify high pressure laminate manufacturer, color, and number.

Other size options available.



Tables, Lounge

Item	SFC No.	Length	Width	Height
Table, Bunching	B-4C-6a	460 (18)	460 (18)	410 (16)
Table, End	B-4C-6b	760 (30)	460 (18)	510 (20)
Table, Corner	B-4C-6c	760 (30)	760 (30)	510 (20)
Table, Coffee	B-4C-6d	760 (30) dia		410 (16)

Tables, Lounge

Intended Use: In Lounges

Manufacturer: **QUALITY METAL WORKS**

SFC No. B-4C-6

Hull Type Drawing No. No. NONE

NSN: NONE

Principal Material:
Aluminum frame and high pressure plastic laminate tops
and side panels

Remarks:

Stainless Steel metal edging flush to table top.

ORDER OPTIONS:

Legs and frame - brushed aluminum or paint color.

Specify high pressure laminate manufacturer, color, and
number.

Custom sizes available.



Table, Coffee

Item	SFC No.	Length	Width	Height
Coffe Table	B-4C-7a	910 (36)	460 (18)	410 (16)
	B-4C-7b	1220 (48)	460 (18)	410 (16)
	B-4C-7c	610 (24) dia		410 (16)
	B-4C-7d	610 (36) dia		410 (16)

Table, Coffee

Intended Use: In Lounges

Manufacturer: **QUALITY METAL WORKS**

SFC No. B-4C-7

Hull Type Drawing No. No. NONE

NSN: NONE

Principal Material:
aluminum frame and high pressure plastic laminate
top.

Remarks:

ORDER OPTIONS:

Frame - polished aluminum or paint color.

Specify high pressure laminate manufacturer, color,
and number



Tables, Coffee

Tables, Lounge

Item	SFC No.	Length	Width	Height
Round Coffee Table	B-4C-8a		910 (36) dia	390 (15-1/2)
Rectangular Coffee table	B-4C-8b	1520 (60)	610 (24)	390 (15-1/2)
Rectangular Curved-Top Coffee Table	B-4C-8c	1520 (60)	610 (24)	390 (15-1/2)

Item	SFC No.	Length	Width	Height
End Table with Shelf		660 (26)	360 (14)	630 (24-3/4)
Coffee Table		910 (36)	460 (18)	480 (18-3/4)

Tables, Coffee

Tables, Lounge
Intended Use: In Lounge Areas

Manufacturer: **QUALITY METAL WORKS**

Intended Use: In Senior Office Quarters

Manufacturer: **QUALITY METAL WORKS**

SFC No. B-4C-11

SFC No. B-4C-8

Hull Type Drawing No.
No. S3306-638243 - End Table with Shelf , S3306-638173 - Coffee Table

Hull Type Drawing No.
No. 805-2217419 - Round coffee table, 805-1648661 - Rectangular coffee table 805-2214460 - Rectangular curved - top

NSN:

NSN: NONE

H2090-00-351-2317 H2090-00-351-2316

Principal Material:
Aluminum frame and high pressure laminate

Principal Material:
Aluminum and high pressure laminate

Remarks:

Remarks:

Cowling: Polished aluminum or stainless stell.

Design matches cabin extension table, Hull Type Drawing No. S3302-631493 and end tables SFC No. B-4C- 1.

ORDER OPTIONS:

*Other sizes fabricated to order.

Frame - brushed aluminum or paint (color).

ORDER OPTIONS:

Specify high pressure laminate manufacturer, color, and number.

Specify high pressure laminate manufacturer, color, and number.



Table, Solid Top

Item	SFC No.	Length	Width	Height
Size I, Type A		1520 (60)	760 (30)	760 (30)
Size II, Type A (shown)		1830 (72)	760 (30)	760 (30)
Size I, Type B		1520 (60)	760 (30)	760 (30)
Size II, Type B		1830 (72)	760 (30)	760 (30)

Table, Solid Top

Intended Use: In Work Spaces, Offices

Manufacturer: **QUALITY METAL WORKS**

SFC No. B-4D-1

Hull Type Drawing No. No. S3209-961226

NSN: NONE

Principal Material:
Aluminum and high pressure plastic laminate

Remarks:

Type A, Sizes I & II fitted with drawers as shown in the illustration.

Type B, Sizes I & II are not fitted with drawers.

Lee rails not provided.

Legs adjustable for sheer and camber.

ORDER OPTIONS:

Specify high pressure laminate manufacturer, color and number.



Custom 36" width available.

Table, Writing, with Drawer

Item	SFC No.	Length	Width	Height
Table, with drawers		810 (32)	530 (21)	760 (30)
Drawer (interior)		460 (18)	410 (16-1/8)	80 (3)
Table, without drawers		1140 (45)	760 (30)	740 (29)
		910 (36)	760 (30)	740 (29)
		760 (30)	760 (30)	740 (29)

Table, Writing, with Drawer

Intended Use: Utility Tables

Manufacturer: **QUALITY METAL WORKS**

SFC No. B-4D-4

Hull Type Drawing No.

No. S3306-638434 (with or without drawers)

NSN:

NONE (without drawers)

Principal Material:
Aluminum and high pressure laminate

Remarks:

Lee rails not provided.

Legs adjustable for sheer and camber.

ORDER OPTIONS:

Table - with or without drawers.

Frame - brushed aluminum or paint (color).

Specify high pressure laminate manufacturer, col number and texture.



Table, Writing, Bulkhead-mounted

Item	SFC No.	Length	Width	Height
		1020 (40)	410 (16)	540 (21-1/4)
Writing Surface				760 (30)

Table, Writing, Bulkhead-mounted

Intended Use: Where Required

Manufacturer: **QUALITY METAL WORKS**

SFC No. B-4D-5

Hull Type Drawing No. No. 805-1645299

NSN: NONE

Principal Material:
Aluminum and high pressure laminate

Remarks:

Table is bulkhead - mounted.

*Length of tables vary to suit installations.

Mounting support brackets are spaced on 36" centers for tables exceeding the width shown.

Privacy partitions are spaced 20" apart.

A sketch should be forwarded with requisition if table is of odd configuration to suit arrangement.

Table should be mounted so that writing surface is 30" above the deck if used with chair.

42" above deck for standing.

ORDER OPTIONS:

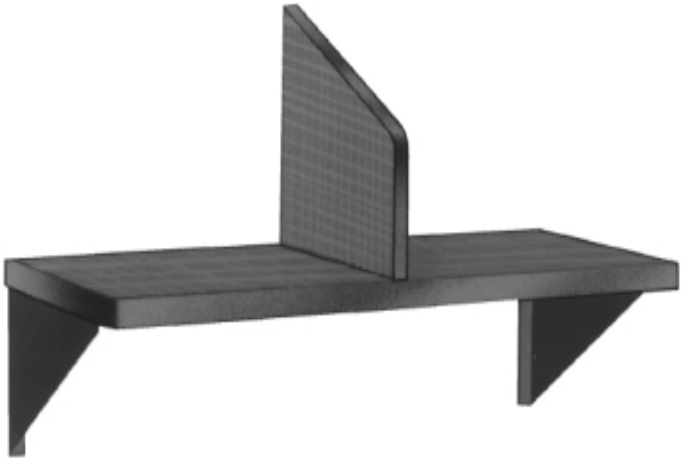

Tables, Chart, Modular

Item	NSN	Width	Depth	Height
Group 5 (as shown)	None	1420 (56)	1090 (43)	1040 (41)
Type A Module	1H2090-00-103-2497	710 (28)	910 (36)	930 (36-3/4)
Type B Module	1H2090-00-103-2498	710 (28)	910 (36)	650 (25-7/16)
Type C Module	1H2090-00-103-2500	360 (14)	910 (36)	290 (11-5/16)
Type D Module	1H2090-00-103-2499	360 (14)	910 (36)	290 (11-5/16)
Top, Chronometer-left	1H2090-00-016-7660	1420 (56)	1090 (43)	30 (1-5/16)
Top, Chronometer right	1H2090-00-016-7662	1420 (56)	1090 (43)	30 (1-5/16)
Top, w/out chronometer	1H2090-00-016-7669	1420 (56)	1090 (43)	30 (1-5/16)
Top, Chronometer-left	1H2090-00-016-7666	2130 (84)	1090 (43)	30 (1-5/16)
Top, Chronometer-right	1H2090-00-016-7665	2130 (84)	1090 (43)	30 (1-5/16)
Top w/out Chronometer	1H2090-00-016-7663	2130 (84)	1090 (43)	30 (1-5/16)
Deck to work surface				100 (4-16)
Skirt (upstand) along				
Back edge of top				80 (3)
Overall height incl. skirt				1090 (43-1/16)

Tables, Chart, Modular

Tables, Chart, Modular

Tables, Chart, Modular

Intended Use:
In Navigation Spaces

Manufacturer: **QUALITY METAL WORKS**

SFC No.
B-4D-6

Hull Type Drawing No.
No. 805-921996 , 805-4597954 (sub-base details)

NSN:

Principal Material:
Aluminum and high pressure plastic laminate

Remarks:

Four basic modules, with tops and subbases may be ordered to form variously configured groups.

Group No. 5 (shown) is a typical composite assembly utilizing the four basic modules.

Can be ordered with or without chronometer stowage.

Refer to Hull Drawing for configuration of other groups.

Type A consists: Cabinet and drawer unit (25-7/8' high). Cabinet (27" high) contains 3 adjustable shelves.

Type B consists of: Three drawer unit (25 7/8' high). Top drawer with center lock.

Type C consists of: Chronometer storage.

Type D consists of: Drawer with lock.

ORDER OPTIONS:

Specify plastic laminate manufacturer, color, and number.

Specify group or module, top, and base as required.



Study Carrel

Item	SFC No.	Length	Width	Height
Study Carrel	B-4D-7	760 (30)	510 (20)	1320 (52)

Study Carrel

Intended Use: Libraries, Lounges, and Study Areas

Manufacturer: **QUALITY METAL WORKS**

SFC No.
B-4D-7

Hull Type Drawing No.
No. NONE

NSN:
NONE

Principal Material:
Aluminum, high pressure plastic laminate

Remarks:

Study carrel includes duplex receptacle and light.

ORDER OPTIONS:

Specify high pressure laminate manufacturer, color, and number for study carrel body.

Legs - brushed aluminum or paint color.

Custom sizes available.



Multimedia Stowage Cabinets

Item	SFC No.	Length	Width	Height
Multimedia Cabinets	B-4E-2a	940 (37)	470 (18-3/8)	1880 (74)
	B-4E-2b	940 (37)	470 (18-3/8)	1520 (60)
	B-4E-2c	940 (37)	470 (18-3/8)	1170 (46)
	B-4D-2d	940 (37)	470 (18-3/8)	790 (31)

Multimedia Stowage Cabinets

Intended Use:

In Computer Areas for the storage of reels, disk cartridges, tape, disk, packs, diskettes, printout binders, cassettes, microfilm and letter/legal filing shelves.

Manufacturer: **QUALITY METAL WORKS**

SFC No. B-4E-2

Hull Type Drawing No. NONE

NSN: NONE

Principal Material:
Steel

Remarks:

*NOT RECOMMENDED FOR WEIGHT CRITICAL SHIPS

ORDER OPTIONS:

Procuring activity to specify specific filing components required.

Sub-base required for deck attachment.



P. C. Cabinet

Item	SFC No.	Width	Depth	Height
Cabinet	B-4E-3a	860 (34)	610 (24)	1650 (65)
Security Cabinet w/Pad-lock	B-4E-3b	860 (34)	610 (24)	1650 (65)

P. C. Cabinet

Intended Use:

In Offices, Work Stations, and Computer Area

Manufacturer: **QUALITY METAL WORKS**

Data-Mate, Inc.

Alternate Source:

Noted manufacturer submitted photograph. Alternate sources are listed in the Sources for Shipboard Furniture link.

SFC No.

B-4E-3

Hull Type Drawing No.

No. NONE

NSN:

NONE

Principal Material:

20 GA steel

Remarks:

Ventilation slots in top and rear of cabinet.

All internal components adjustable in 1" increments.

Slotted printer shelf with 90 degree reorientation feature.

Security cabinet has three-position dial changeable combination lock.

Sub-base required for deck attachment.

ORDER OPTIONS:

Type cabinet.



Computer Cabinet

Item	SFC No.	Width	Depth	Height
P. C. Cabinet, low	B-4E-4	760 (30)	610 (24)	1250 (49-3/8)
P. C. Cabinet, high		760 (30)	610 (24)	1540 (60-1/2)

Computer Cabinet

Intended Use:

In Offices, Work Stations, and Computer Area

Manufacturer: **QUALITY METAL WORKS**

SFC No. B-4E-4

Hull Type Drawing No. No. NONE

NSN: NONE

Principal Material:

20 GA steel, aluminum

Remarks:

*NOT RECOMMENDED FOR WEIGHT CRITICAL SHIPS.

Roll-up locking aluminum tambour door.

ORDER OPTIONS:

Size.

Dual air circulation fans.

Steel fld-down work surfaces.

Color-tan or grey.

Sub-base required for deck attachment.



Computer Cabinet

Item	SFC No.	Width	Depth	Height
Multi-Media Cabinet	B-4E-5a	910 (36)	470 (18-1/2)	810 (32)
	B-4E-5b	910 (36)	470 (18-1/2)	1120 (44)
	B-4E-5c	910 (36)	470 (18-1/2)	1370 (54)
	B-4E-5d	910 (36)	470 (18-1/2)	1570 (62)
	B-4E-5e	910 (36)	470 (18-1/2)	1730 (68)
	B-4E-5f	910 (36)	470 (18-1/2)	1880 (74)

Computer Cabinets
Intended Use:

In Offices, Work Stations, and Computer Area

Manufacturer: **QUALITY METAL WORKS**

SFC No. B-4E-5

Hull Type Drawing No.
No. NONE

NSN: NONE

Principal Material:
18 GA steel, aluminum

Remarks:

Roll-up locking aluminum tambour door.

ORDER OPTIONS:

Size.

Color-tan or grey.

Consult manufacturer for complete list of options.

Sub-base required for deck attachment



Desk, Flat Top, Double Pedestal

Item	SFC No.	Length	Width	Height
Desk, overall		1370 (54)	760 (30)	880 (34-1/2)
Work surface above deck				770 (30-1/2)

Desk, Flat Top, Double Pedestal

Intended Use: In Office Spaces

Manufacturer: **QUALITY METAL WORKS**

SFC No. B-5A-1

Hull Type Drawing No. No. S3209-633117

NSN: H2090-00-355-4843

Principal Material:

Aluminum, high pressure laminate

Remarks:

Two pull-out shelves.

File drawer is fitted with a compressor.

4 inch splash integral with top.

Legs adjustable for sheer and camber.

ORDER OPTIONS:

Top - specify high pressure laminate, manufacture color and number.

Order Options:



desk, Flat Top, Single Pedestal

Item	SFC No.	Length	Width	Height
Desk, overall		1010 (39-3/4)	760 (30)	880 (34-1/2)
Work surface above deck				760 (30)

desk, Flat Top, Single Pedestal

Intended Use: In Office Spaces

Manufacturer: **QUALITY METAL WORKS**

SFC No. B-5A-2

Hull Type Drawing No. No. 805-2224391

NSN: NONE

Principal Material:
Aluminum and high pressure laminate

Remarks:

File drawer has extension carriage and compressor.

Intermediate drawer has adjustable partitions.

Small drawer has pencil tray.

Pull-out writing shelf.

4" back splash.

Legs adjustable for sheer and camber.

ORDER OPTIONS:

Pedestal - order as shown L. H. or opposite hand R. H.

Top - specify high pressure laminate manufacturer, color, and number.

Frame - brushed aluminum or paint (color).



Desk, Standing, Types A & B

Item	SFC No.	Length	Width	Height
Type A		840 (33)	61 0 (24)	1240 (49)
Type B (shown)		840 (33)	61 0 (24)	1240 (49)

Desk, Standing, Types A & B

Intended Use:

In Issue Rooms and Armory

Manufacturer: **QUALITY METAL WORKS**

SFC No. B-5B-1

Hull Type Drawing No. No. S3209-631336

NSN:

Principal Material:

Aluminum and high pressure laminate

Remarks:

Desks are fitted with two adjustable shelves.

Type A is identical to Type B except that the doors are fitted with a tee handle and is not lockable.

Type B desk (shown) has one shelf, compartmented for nightsticks and small arms.

The cabinet doors can be padlocked.

ORDER OPTIONS

Frame - brushed aluminum or paint (color).

Top - specify high pressure laminate manufacturer, color, and number.

Order Options:



Desk, Log, with Hinged Top

Item	SFC No.	Length	Width	Height
Desk, log		620 (24-1/2)	550 (21-3/4)	460 (18)
Writing surface				1070 (42)

Desk, Log, with Hinged Top
Intended Use: Various Locations

Manufacturer: **QUALITY METAL WORKS**

SFC No.
B-5B-2

Hull Type Drawing No.
No. S3209-634554

NSN:
NONE

Principal Material:
Aluminum and high pressure laminate

Remarks:

Top hinges upward for access to stowage compartment.

Bulkhead mounted.

Recommended height above deck for stand up use.

ORDER OPTIONS:

Frame - brushed aluminum or paint (color).

Top - specify high pressure laminate, manufacturer, color, and number

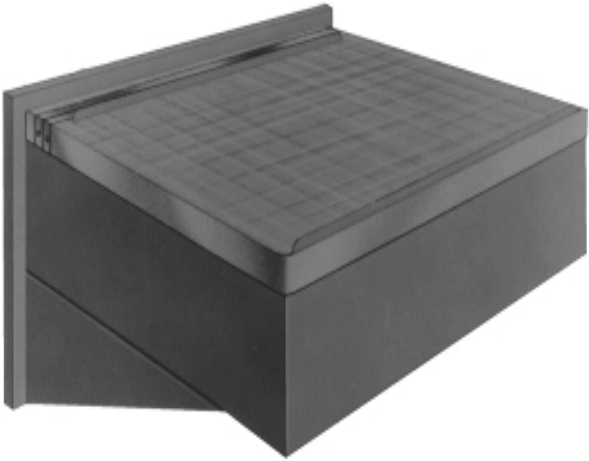

Desk, Log, with Drawer

Item	SFC No.	Length	Width	Height
Desk, log		770 (30-1/4)	700 (27-3/4)	460 (18)
Writing surface				1070 (42)*

Desk, Log, with Drawer

Intended Use: Various Locations

Manufacturer: **QUALITY METAL WORKS**

SFC No. B-5B-3

Hull Type Drawing No. No. S3209-633953

NSN: H2090-00-355-4845

Principal Material:
Aluminum and high pressure laminate

Remarks:

Bulkhead mounted.

Drawer can be fully extended.

*Recommended height above deck for stand up use.

ORDER OPTIONS:

Frame - brushed aluminum or paint (color).

Top - specify high pressure laminate, color, and number.



Desk, Log, Drop Leaf

Item	SFC No.	Length	Width	Height
Working position		620 (24-1/4)	550 (21-3/4)	520 (20-3/8)
Folded position		620 (24-1/4)	140 (5-1/2)	520 (20-3/8)
Writing surface				1,070 (42)*

Desk, Log, Drop Leaf

Intended Use: Various Locations

Manufacturer: **QUALITY METAL WORKS**

SFC No. B-5B-4

Hull Type Drawing No. No. S3209-866181

NSN: 2090-00-355-4844

Principal Material:
See Appendix for list of sources.

Remarks:

Bulkhead mounted.

Two-part folding support arms

*Recommended height above deck for stand-up use.

ORDER OPTIONS:

Fame - brushed aluminum or paint (color).

Top - specify high pressure laminate, manufacturer, an number.

Order Options:

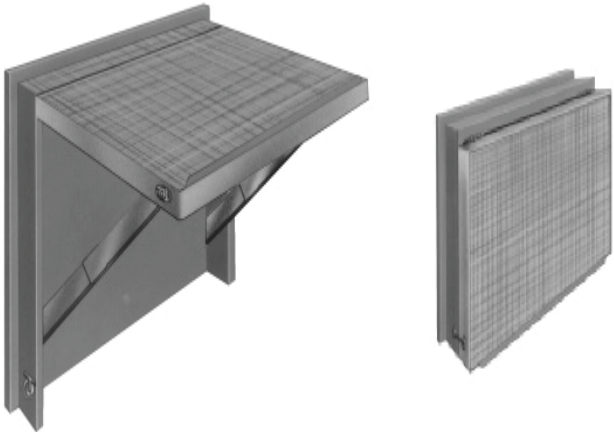

Booth, Telephone, and Intergral Log Desk

Item	SFC No.	Length	Width	Height
		790 (31)	740 (29)	1020 (40)

Booth, Telephone, and Intergral Log Desk

Intended Use: In High Noise Level Areas

Manufacturer: **QUALITY METAL WORKS**

SFC No. B-5B-5

Hull Type Drawing No. No. 804-1632788

NSN: NONE

Principal Material:
aluminum, and high presure plastic laminate

Remarks:

Booth is accoustically insulated.

Drawer beneath the log desk is used for notes, supplies, records, etc.

Bulkhead mounted.

ORDER OPTIONS:

Top - specify high pressure laminate, manufacturer, color, and number.

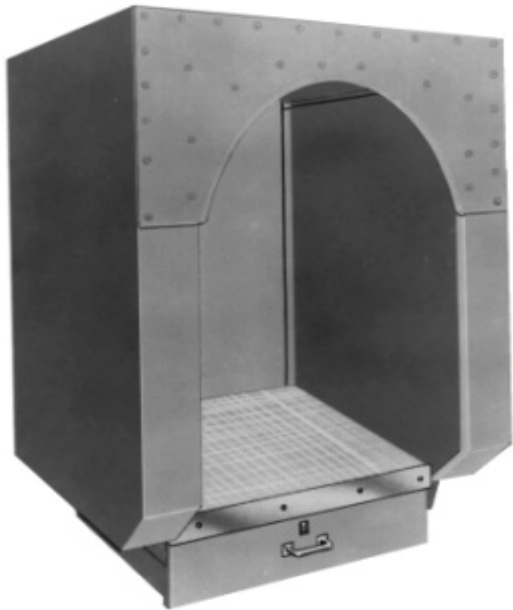

Cabinet, Plan

Item	SFC No.	Width	Depth	Height
Type A 3 drawers		460 (18)	790 (31)*	1010 (39-3/4)
Type B 6 drawers		910 (36)	790 (31)*	1010 (39-3/4)
Type C 9 drawers		1370 (54)	790 (31)*	1010 (39-3/4)
Type D 12 drawers		1830 (72)	790 (31)*	1010 (39-3/4)
Type E 15 drawers (shown)		2290 (90)	790 (31)*	1010 (39-3/4)

Cabinet, Plan

Intended Use: In Engineering Office

Manufacturer: **QUALITY METAL WORKS**

SFC No. B-6A-2

Hull Type Drawing No. No. S3201-632481

NSN: None

Principal Material:

Aluminum, high pressure laminate

Remarks:

Each type cabinet is provided with a common top and su base.

All drawers are fitted with compressors and can be fully extended.

*Units may serve as a service counter by specifying a 34 wide flat top in lieu of the top with back splash.

ORDER OPTIONS:

Top - Specify high presssure laminate manufacturer, colc and number.



Locker, Cleaning Gear or Battle Dressing Stowage

Item	SFC No.	Length	Width	Height
		610 (240)	460 (18)	1780 (70)

Locker, Cleaning Gear or Battle Dressing Stowage

Intended Use:

Cleaning Gear Locker or Battle Dressing Station

Manufacturer: **QUALITY METAL WORKS**

SFC No. B-6A-1

Hull Type Drawing No. No. 805-1648663

NSN: 2090-00-115-5148

Principal Material:

Aluminum

Remarks:

Locker has a vertical partition 8" from right side and provides stowage for mops, brooms, splints, etc.

Four fixed shelves.

Removable bottom for deck maintenance and inspection

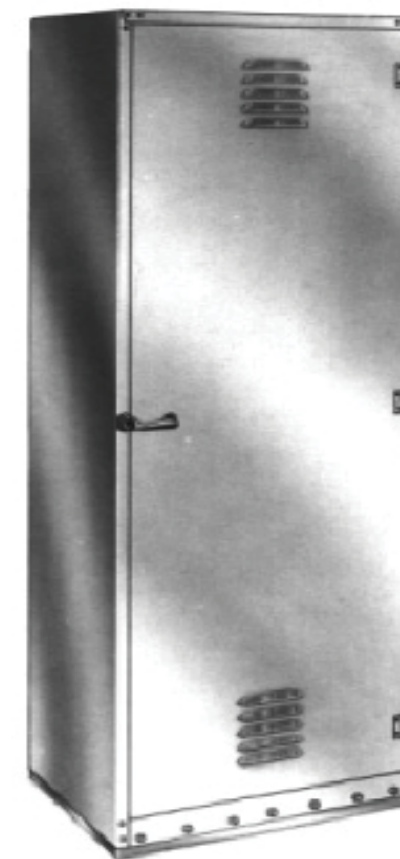

Cabinet, Stationery

Cabinet, Form

Item	SFC No.	Width	Depth	Height
		1020 (40)	370 (14-1/2)	790 (31)

Item	SFC No.	Width	Depth	Height
		1070 (42)	460 (18-1/8)	1930 (76)

Cabinet, Stationery

Intended Use:
In Office Spaces

Manufacturer: **QUALITY METAL WORKS**

SFC No.
B-6A-4

Hull Type Drawing No.
No. 805-1749063

NSN:
H2090-00-893-4038

Principal Material:
Aluminum

Remarks:

Bulkhead mounted.

Four adjustable shelves.

Shelves are perforated for placement of dividers to prevent shifting of stock supplies.

Sliding door.



Cabinet, Form

Intended Use:
Storage for Miscellaneous Office Supplies

Manufacturer: **QUALITY METAL WORKS**

SFC No. B-6A-3

Hull Type Drawing No. No. 805-1749005

NSN: NONE

Principal Material:
Aluminum

Remarks:

Two pull-out drawers.

Nine shelves above drawers have adjustable dividers for various size forms.

Two shelves below drawers have a 1" retaining flange around shelf perimeter.
No provision for locking.

ORDER OPTIONS:

Specify sub-base with cabinet

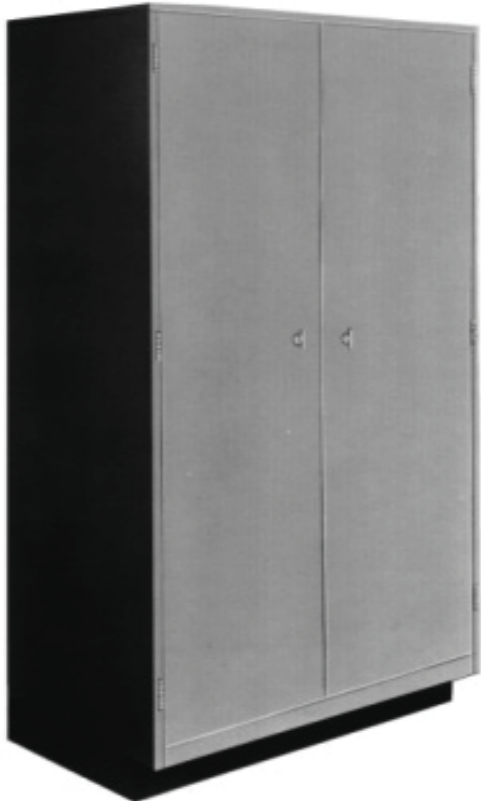

Cabinet, Key, Type A

Item	SFC No.	Width	Depth	Height
		370 (14-1/2)	90 (3-1/2)	500 (19-7/8)

Cabinet, Key, Type A

Intended Use: In Office Spaces

Manufacturer: **QUALITY METAL WORKS**

SFC No. B-6A-5

Hull Type Drawing No. No. NONE

NSN: NONE

Principal Material:
Aluminum

Remarks:

FED SPEC: AA-C-30

Each cabinet comprises:

57 key hooks

1 Loan register

2 Receipt tabs per hook.

2 Fabric key tabs per hook.

(1 temporary for loan and 1 permanent tab to be retained in cabinet).

Bulkhead mounted.

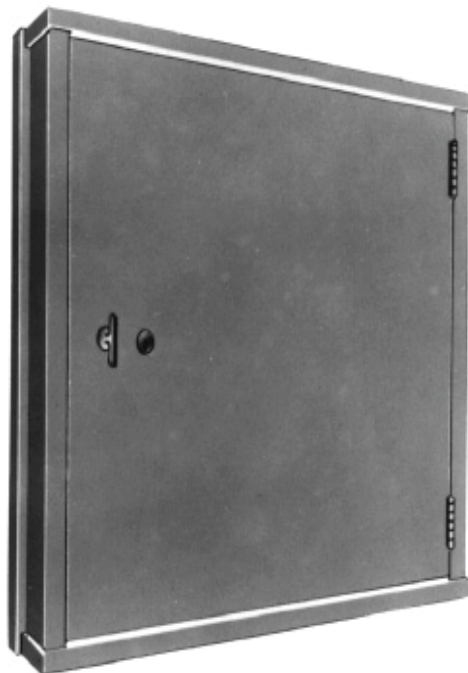

Cabinet, Key, Type E

Item	SFC No.	Width	Depth	Height
		100 (4)	80 (3)	100 (4)

Cabinet, Key, Type E

Intended Use:

To Provide Emergency Access to Locked Compartments

Manufacturer: **QUALITY METAL WORKS**

SFC No. B-6A-6

Hull Type Drawing No. S3209-860194

NSN: H2090-00-904-6699

Principal Material:
Aluminum, glass

Remarks:

Cabinet contains a single key hook.

Cabinet can be padlocked.

Glass cover is provided for break-in during emergencies.

Bulkhead mounted.



Cabinet, Liberty Card

Item	SFC No.	Width	Depth	Height
		500 (19-1/2)	110 (4-3/8)	650 (25-1/2)

cabinet, Liberty Card

Intended Use:
Quarter Deck and Offices

Manufacturer: **QUALITY METAL WORKS**

SFC No.
B-6A-7

Hull Type Drawing No.
S3209-630008

NSN:
H2090-00-355-4841

Principal Material:
Aluminum

Remarks:

Capacity: 336 card clips.

Three hinged panels pivot out for ease of access.

Cabinet door is provided with lock.

Unit designed for bulkhead mounting.

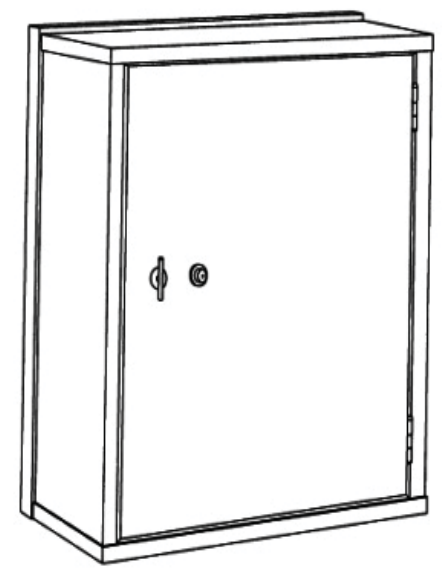

Bookcase, 48"

Item	SFC No.	Width	Depth	Height
		1220 (48)	290 (11-3/8)	1880 (74)

Bookcase, 48"

Intended Use:
Books or Document Stowage

Manufacturer: **QUALITY METAL WORKS**

SFC No.
B-6A-8

Hull Type Drawing No.
S3306-633490

NSN:
H2090-00-269-1239

Principal Material:
Aluminum

Remarks:

Five adjustable shelves.

Shelf adjustments can be made in increments of 1 inch.

Removable bottom is provided for deck inspection

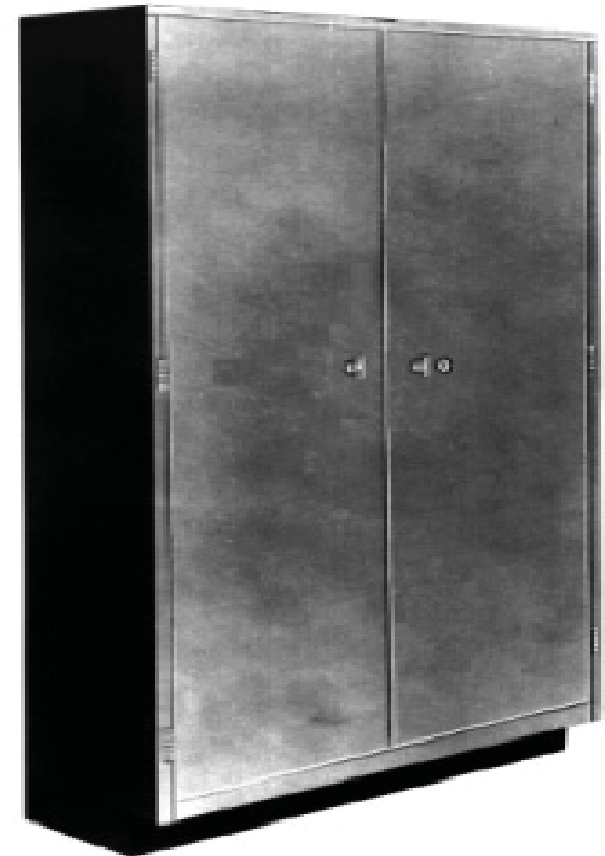

Bookcases, Sectional, Types A, B & C

Item	SFC No.	Width	Depth	Height
Type A		910 (36)	330 (13)	340 (13-1/2)
Type B		910 (36)	330 (13)	390 (15-1/2)
Type C		910 (36)	330 (13)	440 (17-1/2)
Base		910 (36)	330 (13)	260 (10-3/8)
Top		910 (36)	330 (13-1/8)	60 (2-1/4)
Assembly shown consists of 3 sections type A, top and base		910 (36)	330 (13)	1300 (51)

Bookcases, Sectional, Types A, B & C

Intended Use: In Office Spaces

Manufacturer: **QUALITY METAL WORKS**

SFC No. B-6A-9

Hull Type Drawing No. S3209-636616

NSN: NONE

Principal Material:
Aluminum

Remarks:

Section are stackable and interlocking.

ORDER OPTIONS:

Specify top, base, and number of sections.



Cabinet, Napkin (Capacity 30 to 50)

Item	SFC No.	Width	Depth	Height
30 Napkins		500 (19-3/4)	180 (7-1/4)	390 (15-1/2)
35 Napkins		500 (19-3/4)	180 (7-1/4)	440 (17-1/2)
40 Napkins		500 (19-3/4)	180 (7-1/4)	500 (19-1/2)
45 Napkins		500 (19-3/4)	180 (7-1/4)	550 (21-1/2)
50 Napkins		500 (19-3/4)	180 (7-1/4)	600 (23-1/2)

Cabinet, Napkin (Capacity 30 to 50)

Intended Use: BIn Wardrooms

Manufacturer: **QUALITY METAL WORKS**

SFC No. B-6A-12

Hull Type Drawing No. No. S3306-637770

NSN: NONE

Principal Material:
Aluminum

Remarks:

Cabinets are compartmented for the number of
kins required.

Compartment number matches the napkin ring
ber for positive identification.

Bulkhead mounted.

Napkin rings are included.

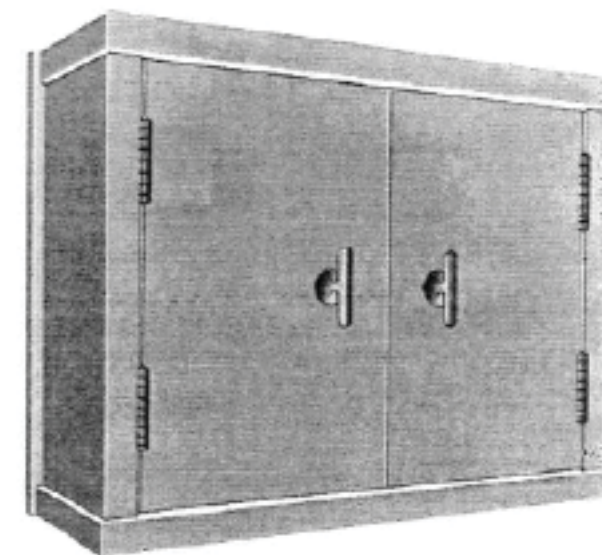

Cabinets, Napkin (Capacity 100 to 130)

Item	SFC No.	Width	Depth	Height
100 Napkins		910 (36)	180 (7-1/4)	600 (23-1/2)
110 Napkins		910 (36)	180 (7-1/4)	650 (25-1/2)
120 Napkins		910 (36)	180 (7-1/4)	700 (27-1/2)
130 Napkins		910 (36)	180 (7-1/4)	750 (29-1/2)

Cabinets, Napkin (Capacity 100 to 130)

Intended Use: In Wardrooms

Manufacturer: **QUALITY METAL WORKS**

SFC No. B-6A-13

Hull Type Drawing No. S3306-637771

NSN: NONE

Principal Material:
Aluminum

Remarks:

Bulkhead mounted.

Cabinets are compartmented for the number of napkins required.

Compartment number matches the napkin ring number for positive identification.

Napkin ring are included.



Lockers, Chronometer, types A, B & C

Item	NSN	Width	Depth	Height
Type A	H2090-00-224-6800	300 (11-3/4)	300 (11-3/4)	280 (10-15/16)
Type B (shown)	H2090-00-224-6801	540 (21-3/8)	300 (11-3/4)	280 (10-15/16)
Type C	NONE	790 (31-1/8)	300 (11-3/4)	280 (10-15/16)

Lockers, Chronometer, types A, B & C

Intended Use:

In Chart House and Vantage Points

Manufacturer: **QUALITY METAL WORKS**

SFC No. B-6A-14

Hull Type Drawing No. S2407-475127

NSN:

Principal Material:
Aluminum

Remarks:

Each locker is fitted with rubber padded supports to receive the gimbal boxes that house the chronometers.

Type A is a single compartment locker.

Type B is a double compartment locker.

Type C is a triple compartment locker.

ORDER OPTIONS:

Specify size - Type A, B, or C.

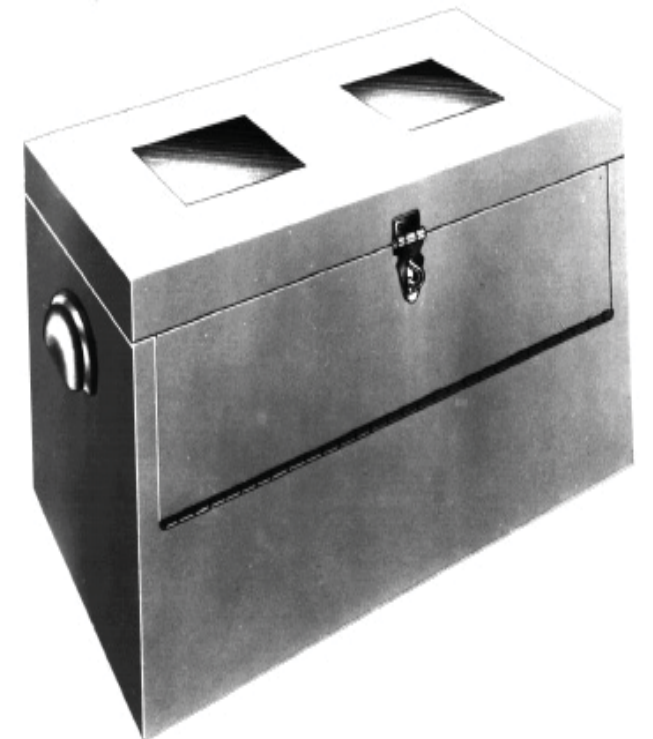



5622 Powell St. • New Orleans, LA 70123 • 504.734.7216 Office